

# EV CHARGER CARO PRO 3PH 22kW User Manual



## General instructions

This manual contains important safety instructions that must be followed during installation and maintenance of the equipment.

## Please keep these instructions!

This manual must be considered an integral part of the equipment, and must be available at all times to everyone who interacts with the equipment. The manual must always accompany the equipment, even when it is transferred to another user or plant.

## Copyright statement

Copyright of this manual belongs to Zucchetti Centro Sistemi S.p.A. No part of this manual may be copied (including the software), reproduced or distributed in any form or by any means without the permission of Zucchetti Centro Sistemi S.p.A. All rights reserved. ZCS reserves the right to final interpretation. This manual is subject to change based on feedback from users, installers or customers. Please check our website at <http://www.zcsazzurro.com> for the latest version.

## Technical support

ZCS offers a support and technical consultancy service accessible by sending a request directly from the website [www.zcsazzurro.com](http://www.zcsazzurro.com)

The following toll-free number is available for the Italian territory: 800 72 74 64.

# Table of Contents

|   |    |
|---|----|
| 1. Safety instructions .....                        | 8  |
| 1.1. Safety and Warnings.....                       | 8  |
| 1.2. Safety instructions .....                      | 10 |
| 1.3. Symbols and icons .....                        | 13 |
| 1.4. Labels .....                                   | 14 |
| 2. Product Overview .....                           | 15 |
| 2.1. Product Features .....                         | 15 |
| 3. Exterior Overview .....                          | 18 |
| 4. Technical Specification - Datasheet .....        | 19 |
| 5. Installation .....                               | 20 |
| 5.1. Checks before installation .....               | 20 |
| 5.2. Required Cable and Accessory .....             | 23 |
| 5.3. Installation tools .....                       | 24 |
| 5.4. Installation position .....                    | 26 |
| 5.5. Movement of the charger .....                  | 26 |
| 6. Installation Guide .....                         | 27 |
| 6.1. Recommended installation height .....          | 27 |
| 6.2. Wiring .....                                   | 27 |
| 6.3. Connect RS485 cable .....                      | 29 |
| 6.4. Connect Ethernet cable & Insert SIM card ..... | 30 |
| 6.5. Install charger .....                          | 30 |
| 7. Configure the Charger.....                       | 33 |
| 7.1. Configuration by AP mode .....                 | 33 |
| 7.1.1. Preparation.....                             | 33 |
| 7.1.2. Login .....                                  | 33 |
| 7.2. Commercial Scenario.....                       | 35 |
| 7.2.1. Evcharge platform .....                      | 35 |



- 7.2.2. Third-Party Platform .....36
- 7.2.3. Use 4G for Communication .....38
- 7.2.4. Use Wifi for Communication .....39
- 7.2.5. Use Ethernet for Communication.....40
- 7.3. Residential Scenario .....41
  - 7.3.1. Evcharge APP configuration .....41
  - 7.3.2. Sign Up and Log In .....41
  - 7.3.3. Bind Charger to App .....42
  - 7.3.4. Select Communication Mode .....43
  - 7.3.5. Set Maximum Charging Current .....44
  - 7.3.6. Transfer Ownership to End User .....44
  - 7.3.7. Set the RFID Card .....45
  - 7.3.8. Charging Operation .....46
- 8. Dynamic Load Balancing .....50
  - 8.1. Wiring for Dynamic Load Balancing.....50
    - 8.1.1. Introduction Load Balancing.....50
    - 8.1.2. Applicable Scenarios and Required Accessories .....51
    - 8.1.3. Specifications.....52
    - 8.1.4. Hardware Wiring .....53
      - Load balancing via meter only .....53
      - Caro\_Three phases\_Meter + CT.....54
  - 8.2. Software configuration.....54
    - 8.2.1. Configured via APP .....55
    - 8.2.2. Configured via AP mode .....56
- 9. Indicator .....58
- 10. Troubleshooting .....59
- 11. Maintenance .....61
  - 11.1. Storage and Transportation.....61
  - 11.2. Disassembly .....62
  - 11.3. Disposal/Scrapping .....62

12. Warranty .....62

## Preface

### General information

Please read this manual carefully before installation, use or maintenance. This manual contains important safety instructions that must be followed during installation and maintenance of the system.

### Scope

This manual describes the assembly, installation, electrical connection, commissioning, maintenance and troubleshooting of the EV CHARGER CARO PRO series:

#### 3PH 22kW



Keep this manual so that it is accessible at all times.



### Recipients

This manual is intended for qualified technical personnel (installers, technicians, electricians, technical support personnel or anyone who is qualified and certified to work on an electrical system), responsible for installing, starting up and operating the charging station.

### Symbols used

This manual provides information for safe operation and uses certain symbols to ensure the safety of personnel and materials, and for efficient use of the equipment during normal operation. It is important to understand this information to avoid accidents and damage to property. Please take note of the following symbols used in this manual.

|   |  |
|---|--|
|  | <p><b>Danger:</b> indicates a hazardous situation which, if not resolved or avoided, could result in serious personal injury or death</p>  |
| <p><b>Danger</b></p>  |  |
|  | <p><b>Warning:</b> indicates a hazardous situation which, if not resolved or avoided, could result in serious personal injury or death</p> |
| <p><b>Warning</b></p>   |  |







|   |  |
|---|--|
|  | <p><b>Caution:</b> indicates a hazardous situation which, if not resolved or avoided, could result in minor or moderate personal injury</p>                    |
| <p><b>Caution</b></p>   |  |
|  | <p><b>Attention:</b> indicates a potentially hazardous situation which, if not resolved or avoided, could result in damage to the system or other property</p> |
| <p><b>Attention</b></p>   |  |
|  | <p><b>Note:</b> provides important tips on the correct and optimal operation of the product</p>  |
| <p><b>Note</b></p>  |  |





## 1. Safety instructions

|   |  |
|---|--|
|  | If you have problems or questions in reading and understanding the following information, please contact Zucchetti Centro Sistemi S.p.A. through the appropriate channels. |
| <b>Note</b>   |  |

### 1.1. Safety and Warnings

Save these instructions. Read all instructions before installing or using the charger.

|   |   |
|---|---|
|    | <b>Keep the charger away from explosive or flammable materials, chemicals, vapours and other hazardous objects</b>  |
|  | <b>Keep the charge point socket clean and dry. If it gets dirty, please wipe it with a clean, dry cloth</b>   |
|  | <b>Do not touch the socket pin when the unit is powered on</b>  |
|  | <b>Do not use the charge point if it is showing any visible product damage such as cracks, abrasions, bare leakage, and other visible defects. At first sight of such damages, immediately contact a qualified technician</b> |
|  | <b>Do not attempt to disassemble, repair or refit the charge point. If necessary, please contact the qualified technician. Improper operation will result in device damage, electric leakage and other hazards</b>            |
|  | <b>In case any abnormal condition happens, please turn off incoming power supplies immediately</b>  |

|   |   |
|---|---|
|    | <p>Please consider charge point protection against lightning and heavy rain</p>   |
|    | <p>Keep children away from the charge point</p>   |
|    | <p>During charging, do not drive the EV. Charge only when the EV is stationary. For hybrid cars, charge only when the engine is switched off</p>  |
|  | <p>Our packaging materials are environmentally friendly and can be recycled. Please put the packaging in applicable containers to recycle it. Do not dispose of this device with the household waste. It should be taken to a suitable facility for recycling of electrical and electronic devices. For more detailed information about recycling of this device, please contact your local city/town council office or your household waste disposal service</p> |

|   |   |
|---|---|
|  | <p>The device can be in electrically energized state. There is risk of shock and electrical hazard. Please strictly observe all warnings on the device and user manuals. The cover of the charge point is only to be removed by a qualified electrician</p> |
| <p><b>Warning</b></p>   |   |

## 1.2. Safety instructions

Highlights the safety instructions to be followed during installation and use of the equipment.

Before installing and using the equipment, make sure you read and understand the instructions in this manual and familiarise yourself with the relative safety symbols shown in this chapter. According to national and local requirements, permission must be obtained from your local provider before connecting to the electrical grid, making sure that the connections are carried out by a qualified electrician. All installation work must be carried out by a qualified and competent electrician.

Contact the nearest authorised service centre for any repairs or maintenance. Contact your distributor for information on the nearest authorised service centre. **DO NOT** carry out repairs yourself, as this may result in injury or damage.

### Qualified personnel

Ensure that the operator has the necessary skills and training to operate the equipment. Personnel responsible for use and maintenance of the equipment must be qualified and capable of performing the activities described, and must also have appropriate knowledge on how to correctly interpret the contents of this manual. For safety reasons, this charging station can only be installed and serviced by a qualified electrician with the necessary training and/or skills and knowledge. Zucchetti Centro Sistemi S.p.A. declines all responsibility for damage to property or personal injury caused by incorrect use of the device.

Do not attempt in any way to repair or replace components of the charging station without the assistance of qualified personnel.

### Installation requirements

Install and start the charging station according to the following instructions. Place the charging station on suitable load-bearing supports with sufficient load capacity (such as metal walls or columns) and make sure it is positioned vertically. Choose a suitable location for the installation of the electrical equipment. Make sure there is sufficient space for heat dispersion and to accommodate future maintenance. Maintain adequate ventilation and ensure that there is enough air circulation for cooling.



**Danger**

**Do not place the charging station near explosive, flammable materials, chemical vapours or potentially hazardous materials.**





Figure 1 – Do not lose or damage this manual

## Transport requirements

If you encounter problems with the packaging that could damage the charging station or if you find any visible damage, immediately notify the transport company. If necessary, request assistance from an installer or from Zucchetti Centro Sistemi S.p.A. Transport of the equipment, especially by road, must be carried out with vehicles suitable to protect the components (in particular, electronic components) against violent knocks, humidity, vibrations, etc.

## Electrical connections



Please follow all the electrical regulations on accident prevention.

|   |  |
|---|--|
|  | <b>Before connecting the electrical cables, make sure to properly disconnect the voltage on the AC connection cables, and do not connect any charging cables for electric vehicles.</b>  |
| <b>Danger</b>   |  |
|  | <b>All installation operations must be carried out by a professional electrician, who has carefully read this manual and understands its contents!</b>   |
| <b>Warning</b>  |  |
|  | <b>Before connecting the charging station to the grid, make sure that all the necessary permits have been obtained from the local grid operator and that all the electrical connections have been completed by a professional electrician.</b> |
| <b>Attention</b>  |  |

|   |  |
|---|--|
|  | <p><b>Do not remove the information label or tamper with the charging station.</b><br/><b>Otherwise, ZCS will not provide any warranty or assistance</b></p> |
| <b>Note</b>   |  |

## Operation

Do not use the product if it has any defects, cracks, scratches or leaks, but contact your dealer or ZCS technical service.

|   |  |
|---|--|
|    | <p><b>Contact with the electrical grid or the terminal of the equipment may cause electrocution or fire!</b></p> <ul style="list-style-type: none"> <li>Do not touch the terminal or the conductor connected to the electrical grid.</li> <li>Follow all the instructions and safety requirements relating to grid connection</li> </ul> |
| <b>Danger</b>   |  |
|  | <p><b>If the charging station is not functioning properly:</b></p> <ul style="list-style-type: none"> <li>Disconnect the input and output power supply</li> </ul>  |
| <b>Warning</b>  |  |
|  | <p><b>Take special care when charging in thunderstorms or in rain</b></p>  |
| <b>Attention</b>  |  |

## Maintenance and repair





Keep the charging station clean and dry; if you need to clean it, use a clean dry cloth. It is very dangerous to touch the inside of the charging station, therefore it is strictly forbidden to do so while the system is running. NEVER clean the inside of the charging station with a wet or damp cloth.

|   |   |
|---|---|
|  | <ul style="list-style-type: none"> <li>Before performing any repairs, disconnect the charging station from the power supply (AC side) and from the data connection to the transmission gate.</li> <li>After switching off the DC switch, wait 5 minutes before carrying out any repairs or maintenance on the charging station</li> </ul> |
| <b>Danger</b>   |   |

|   |  |
|---|--|
|  | <ul style="list-style-type: none"> <li>• The charging station should start working again after any faults have been fixed. For repairs, contact your local authorised service centre</li> <li>• Do not disassemble the internal components of the charging station without permission; this will void the warranty.</li> </ul> |
| <b>Attention</b>  |  |

### 1.3. Symbols and icons

Introduces the main safety symbols on the charging station. Some safety symbols are located on the charging station. Read and understand the contents of the symbols before installation:

|   |   |
|---|---|
|    | Be careful of high voltage  |
|   | Complies with the European Standards  |
|  | Ground connection point   |
|  | Read this manual before installing the charging station.  |
|  | <p>Degree of protection of the equipment according to the IEC 70- 1 standard (EN 60529 June 1997).<br/>IP65 means that it is resistant against water and rust, therefore also suitable for outdoor operation and maintenance.</p> |

**Table 1 – Symbols present on the charger**

## 1.4. Labels

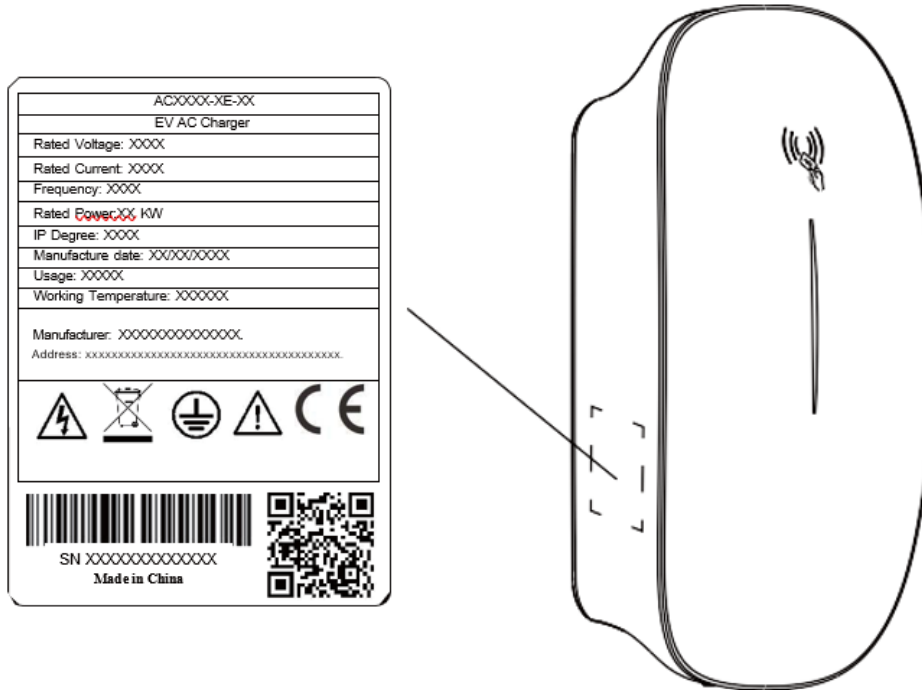

Figure 2 - Labels present on the charging station



**DO NOT** remove the labels. **DO NOT** cover with sheets, supports, cabinets, etc. Always keep them clean and legible.

## 2. Product Overview

The Caro Product specified in this document is design for the market to charge European Standard plug-in electric vehicles (PEVs), plug-in hybrid electric vehicles (PHEVs), and battery electric vehicles (BEVs). It provides EU standard Type 2 AC charger cable connector.

### 2.1. Product Features

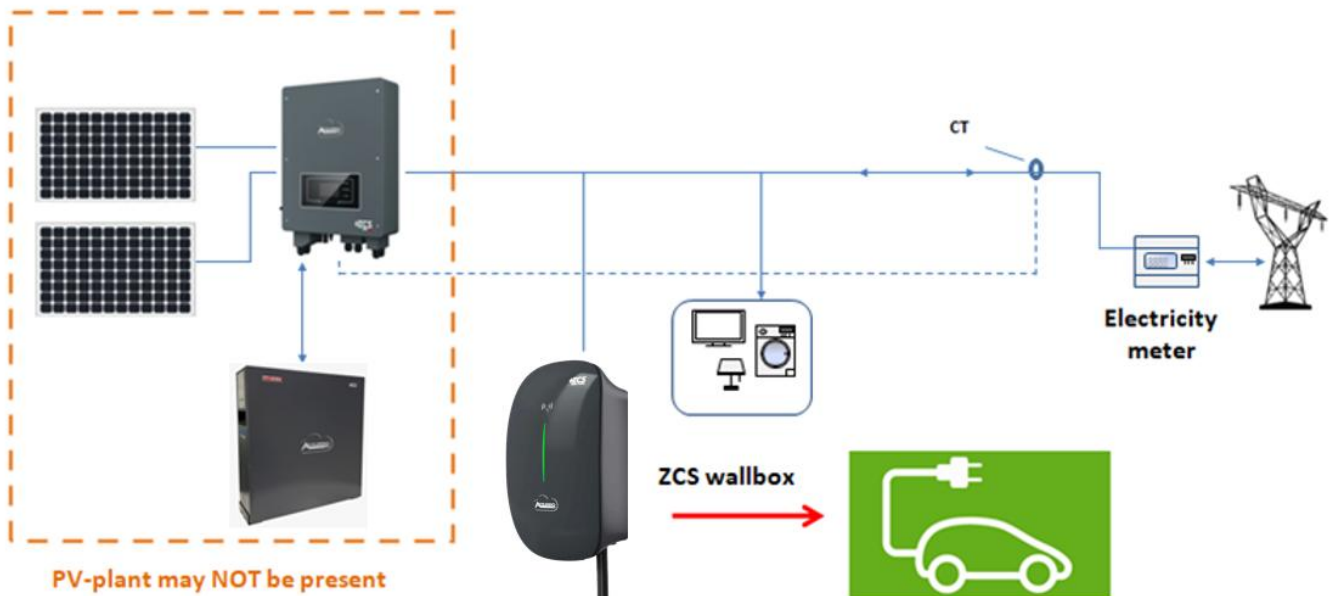



Figure 3 – Example of a charging station connected to a PV system (optional) and grid

- ✓ **Universal Type 2 cable lead.**
- ✓ **Power rating – 22kW**
- ✓ **Adjustable power rating: 22kW: 6~32A.**
- ✓ **Intelligent Authentication:**
  - Support charging user identification on online mode or Bluetooth mode.
  - Smart RFID/Bluetooth/App Authentication.
  - Supports plug to charge while authentication is off.
- ✓ **Multiple charge modes:**
  - Plug to Charge
  - General mode: start charging via RFID card, start charging via App

- Remotely start charging via App
  - Scheduled charge via App
  - Eco Mode\*
  - EMS compatible\*
- ✓ **Built-in LED charging status indicator.**
  - ✓ **Network connectivity: WiFi, Ethernet or 4G.**
  - ✓ **OCPP 1.6 compliant.**
  - ✓ **CE and CB certified.**
  - ✓ **Dynamic Load Balancing:**

The Caro Serials charger has a Dynamic Load Balancing capability which is designed to prevent overloads of the property's power supply when a electric vehicles is being charged.

Once correctly installed and configured, the system will monitor the power being drawn by the charging process and will compare this to the permissible maximum for the property as a whole (need to be set). With this information, the power made available for charging can be dynamically adjusted to reduce the load before the property's maximum load is exceeded.

|   |  |
|---|--|
|  | <ul style="list-style-type: none"> <li>• <b>Load balancing ONLY controls power made available to the VEHICLE. It does not control power to other equipment (home applications) and it is still possible that other equipment cause overload the property's power supply. Please address the source of the equipment that actually caused the overloading.</b></li> <li>• <b>Depending on the manufacturer, electric vehicles need a minimum of around 6 Amps to charge. If the available power is below this level, the vehicle may stop the charge session.</b></li> <li>• <b>In order to monitor the total load, extra current transformer / smart meter are needed.</b></li> <li>• <b>The lower the power available for charging, the more slowly the vehicle will be charged.</b></li> </ul> |
| <b>Attention</b>  |  |

- ✓ **PV energy utilization**

The Caro Pro Series chargers can utilize photovoltaic generation and energy storage technologies to offer a clean, efficient, and reliable power supply for electric vehicles, thereby diminishing reliance on conventional power grids and fostering the adoption of green energy.

This requires extra accessories, please contact our technical support for more information.



Attention

- **PV energy refers to the electricity produced by solar panels that transform sunlight into a usable power source for homes and businesses.**

✓ **Energy management system (EMS) integration**

The Caro Pro Series chargers are designed with dedicated ports to ensure seamless integration with various EMS systems, providing flexible energy management solutions. For details about EMS, please contact our technical support for more information.



Attention

- **The Energy Management System (EMS) is like an intelligent butler that monitors your energy usage, automatically adjusts the operation of devices, and uses energy in the most economical and efficient way, while ensuring safety and reducing waste, helping you save money and protect the environment.**

### 3. Exterior Overview

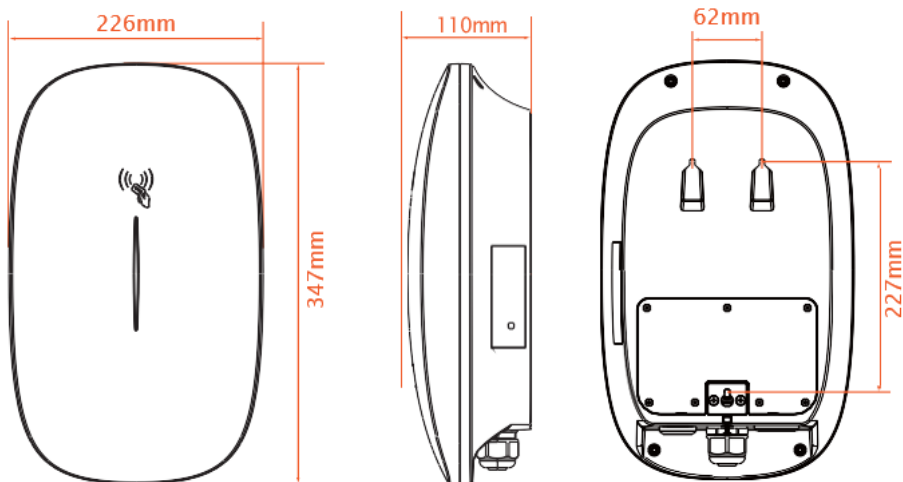
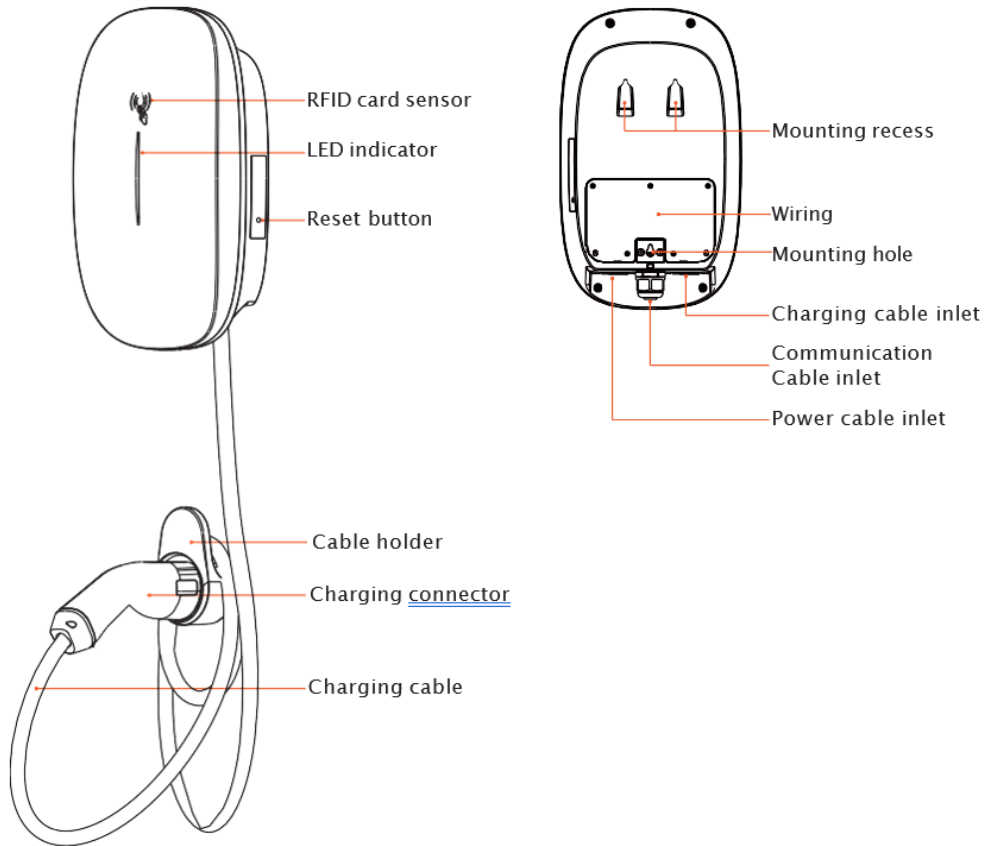

## 4. Technical Specification - Datasheet

| TECHNICAL DATA             |   | ZV3-22K-CARO-CAB                   |
|----------------------------|---|------------------------------------|
| <b>Input</b>               |   |                                    |
| Power Supply               |   | 3P+N+PE                            |
| Rated Voltage              |   | 400V AC                            |
| Rated Current              |   | 32A                                |
| Frequency                  |   | 50 / 60 HZ                         |
| <b>Output</b>              |   |                                    |
| Output Voltage             |   | 400V AC                            |
| Maximum Current            |   | 32A                                |
| Output Power               |   | 22kW                               |
| <b>User Interface</b>      |   |                                    |
| Charge Connector           |   | Type 2 cable                       |
| Cable Length               |   | 7m                                 |
| Housing Material           |   | PC943                              |
| LED Indicator              |   | Green/Yellow/Red                   |
| RFID Reader                |   | Mifare ISO                         |
| Start Mode                 |   | Plug&Play/card RFID/App            |
| <b>Communication</b>       |   |                                    |
| WiFi                       |   | WiFi (2.5Ghz)                      |
| Bluetooth                  |   | Yes                                |
| Ethernet                   |   | Yes                                |
| 4G                         |   | Si                                 |
| Protocol                   |   | Ocpp1.6 Json                       |
| <b>Security and Safety</b> |   |                                    |
| RCD                        |   | 30mA + 6mA DC detection            |
| Ingress Protection         |   | IP65                               |
| Impact Protection          |   | IK08                               |
| Electrical Protection      | Over current protection, Residual current protection, Surge protection, Over/Under voltage protection, Over/Under frequency protection, Over temperature protection   |                                    |
| Certification              | CE, CB, RoHS, Reach, EN 303645  |                                    |
| Certification standard     | IEC 61851-1:2017 EN IEC 61851-1:2019 EN IEC 61851-21-2:2021 EN IEC 61000-6-1:2019 EN IEC 61000-6-3:2007+A1 EN 300 328 V2.2.2:2019 EN 300 330 V2.1.1:2017 EN 301 489-1 V2.2.3:2019 EN 301 489-3 V2.1.1:2019 EN 301 489-17 V3.2.0:2017 EN 62311:2020 BS 7671:2018+A2:2022 |                                    |
| Warranty                   |   | 2 years                            |
| <b>Enironment</b>          |   |                                    |
| Installation               |   | Wall-mount / Pole-mount (Optional) |
| Work Temperature           |   | -30°C~+50°C                        |
| Work Humidity              |   | 5%~95%                             |
| Work Altitude              |   | <2000m                             |
| <b>Package</b>             |   |                                    |
| Product Dimension          |   | 374*226*164 mm (A*L*P)             |
| Package Dimension          |   | 430*330*235 mm (A*L*P)             |
| Net Weight                 |   | 4kg                                |
| Gross Weight               |   | 7kg                                |
| Outer Package              |   | Cardboard box                      |

## 5. Installation



**Danger**

- DO NOT install the charging station near flammable materials.
- DO NOT install the charging station in an area where flammable or explosive materials are stored.

Before the installation, ensure that:

- ✓ The charger power is within the allowed load range of the place.
- ✓ Cables and RCBOs meet the installation and usage requirements.
- ✓ If the AC input power cable exposed to the outdoor environment is 3m or longer, consult the local installer. You are advised to install a surge protective device (SPD) at the upstream of the charger's RCBO.
- ✓ A network cable that is long enough is prepared if the charger is connected to a wired network.
- ✓ The installation area should be covered by a wireless network if the charger is connected to the network through WiFi.

### 5.1. Checks before installation

#### Checking the outer packaging



Packaging materials and components may be damaged during transport. Therefore, it is recommended to check the materials of the outer packaging before installing the charging station. Check the surface of the box for external damage such as holes or tears. If any type of damage is detected, do not open the box containing the charging station and contact the supplier and the courier as soon as possible.

It is also recommended that you check the contents of the packaging and make sure that they correspond to what was declared. If not, contact your dealer to have any missing parts sent to you.

#### Checking the product

After removing the charging station from its packaging, check that the product is intact and complete. If any damage is found or components are missing, contact the supplier and transport company.

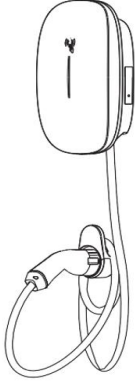
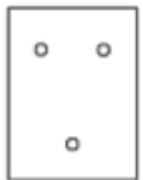
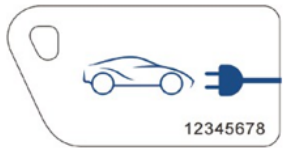
## Contents of the packaging

| No. | Part   | Qty |
|-----|--|-----|
| 1   |  <p>Charging station + cable</p>      | 1   |
| 2   |  <p>Position diagram</p>             | 1   |
| 3   |  <p>RFID activation card</p>        | 2   |
| 4   |  <p>M4*32 Screw &amp; Wall plug</p> | 7   |
| 5   |  <p>Cable holder</p>                | 1   |









|    |   |                            |   |
|----|---|----------------------------|---|
| 6  |    | Allen wrench               | 1 |
| 7  |    | Installation guide         | 1 |
| 8  |    | PIN code label             | 1 |
| 9  |   | Cable clip                 | 1 |
| 10 |  | M3*12 Screw                | 2 |
| 11 |  | Wire ferrule               | 5 |
| 12 |  | Product qualification card | 1 |

Table 2 - Package contents

## 5.2. Required Cable and Accessory

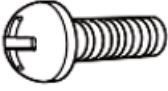





Before installation, you will need to prepare the following accessories and cables on your own:

|   |  |
|---|--|
|  | <ul style="list-style-type: none"> <li>• <b>To facilitate cabling, aluminium wires and solid copper wires are not recommended.</b></li> <li>• <b>Ethernet cable, RJ45 connector, and RS485 cable are necessary solely for the implementation of their respective functions.</b></li> </ul> |
| <b>Attention</b>  |  |

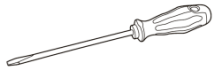
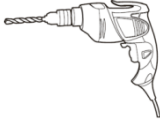
| Item           | Specification  |
|----------------|--|
| Power cable    | Operating current: 32A: Cross section area: $\geq 6\text{mm}^2$        |
| RJ45 connector | Standard   |
| Ethernet cable | Cat 5e or higher, CSA: $0.2 \sim 0.25\text{mm}^2$                      |
| RCBO           | 4P RCBO, C40, 40 A, Type A, 30mA in compliance with local regulations. |
| RS485 cable    | 22 to 24AWG shielded twisted pair                                      |

### 5.3. Installation tools

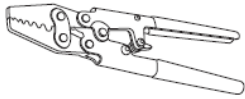
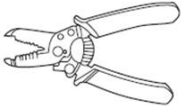
The following tools are required for the installation of the charging station and electrical connections; therefore, they must be prepared before installation.

| No. | Tool  |                       | Function  |
|-----|---|-----------------------|---|
| 1   |    | Screwdriver           | To screw and unscrew screws for the various connections |
| 2   |    | Electric Drill        | To drill holes in the wall for fixing                   |
| 3   |   | Electric screw driver | Fasten the screws                                       |
| 4   |  | Wire cutter           | Cut the cable   |
| 5   |  | Hydraulic clamp       | Clamp the RJ45 connector                                |
| 6   |  | Crimping pliers       | Clamp cord end terminal                                 |
| 7   |  | Wire stripping tool   | To remove the outer sheath of the cables                |
| 8   |  | Rubber hammer         | Drive the wall plugs into the wall                      |





|    |   |                 |  |
|----|---|-----------------|--|
| 9  |    | Multi-meter     | To check the voltage and current values      |
| 10 |    | Marker pen      | To mark the wall for better fixing precision |
| 11 |    | Measuring tape  | Measure the installation height              |
| 12 |    | Level (> 180mm) | To make sure the bracket is level            |
| 13 |   | ESD gloves      | Protective clothing                          |
| 14 |  | Safety goggles  | Protective clothing                          |

Table 3 - Installation tools

|   |  |
|---|--|
|  | <ul style="list-style-type: none"> <li>• <b>The tools are not included with the charger; they are commercially available.</b></li> </ul> |
| <b>Attention</b>  |  |

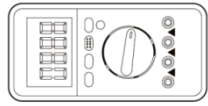
## 5.4. Installation position

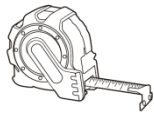
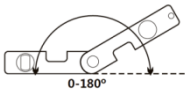
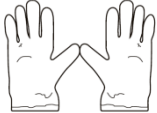
Choose an appropriate installation location for the charging station. Follow the requirements below to determine the installation position.

The installation location chosen should allow easy access to the charging station for normal operation and maintenance.

For safety reasons, ZCS and/or its authorised partners may not perform repairs/maintenance or move the chargers from and to the ground if they are installed at a height of more than 180 cm. Stations installed at higher heights must be moved to the ground before they can be repaired or serviced.

## 5.5. Movement of the charger

- 1) Open the packaging and remove the polystyrene protection cover, insert your hands into the slots and take hold of the device;
- 2) Lift the charging station from its packing box and move it to the installation position, then remove the polystyrene protections.



Attention

- **To prevent damage and personal injury, hold the device securely when moving as it is a heavy piece of equipment**
- **Always position the device horizontally**
- **Please note that the installation drawings are for illustrative purpose only, and the actual installation should be based on the physical charger.**
- **Please note that the internal structure of the charger may differ based on the supported communication methods.**

## 6. Installation Guide

### 6.1. Recommended installation height

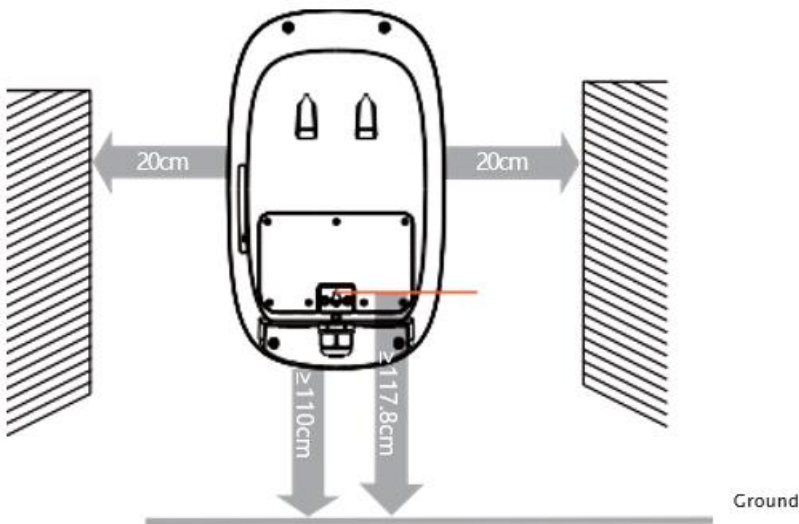

### 6.2. Wiring

|   |  |
|---|--|
|  | <ul style="list-style-type: none"> <li>• <b>The IT system is optional</b></li> </ul> |
| <b>Attention</b>  |  |

TN and TT systems are configured with neutral conductors. IT systems do not have neutral conductors.

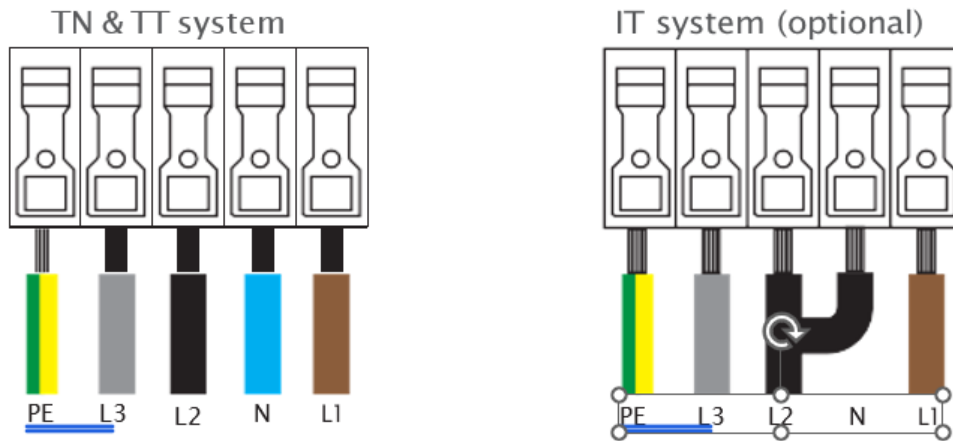

|  |  |
|--|--|
|  | <ul style="list-style-type: none"> <li>• For IT system, the L2 and N needs to be short-circuited, and if a RCBO is installed, L2 and N needs to be short-circuited at the input side of the RCBO.</li> <li>• Ensure that the wire for short-circuit connection is of same specification as the other wires.</li> </ul> |
| Attention  |  |

There are two methods to connect the power cable:

- With wire ferrules

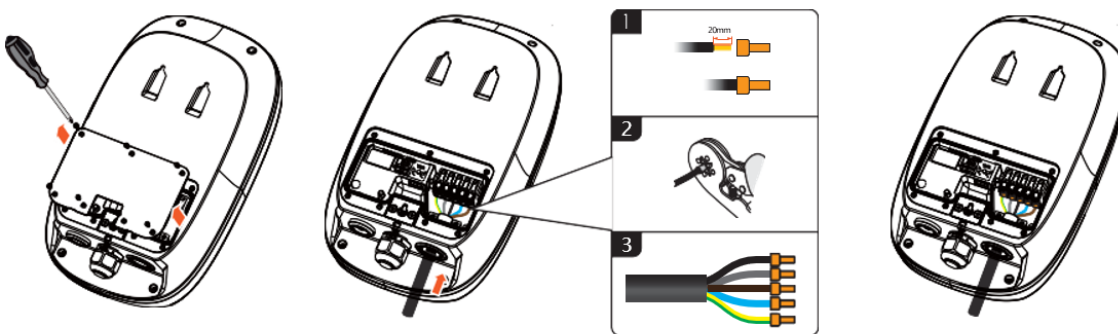

- Without wire ferrules

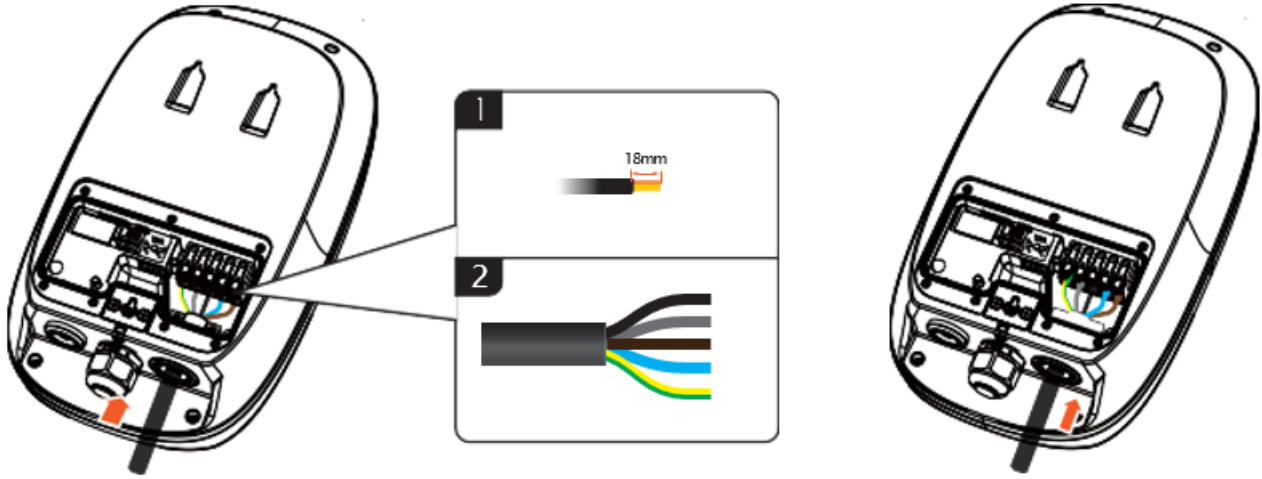

**Attention**

- The step 6.3 and 6.4 are only required when you need to implement the corresponding function.

### 6.3. Connect RS485 cable

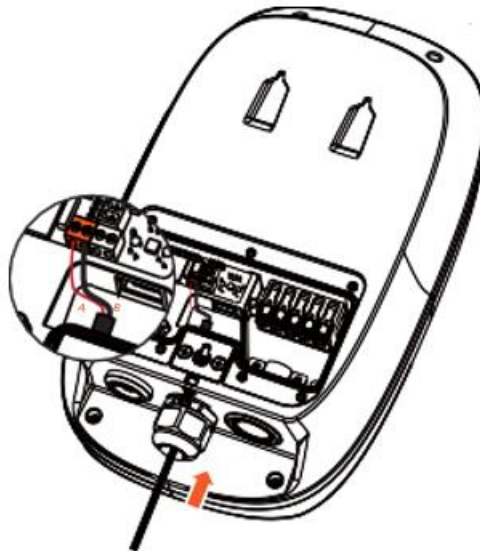

## 6.4. Connect Ethernet cable & Insert SIM card

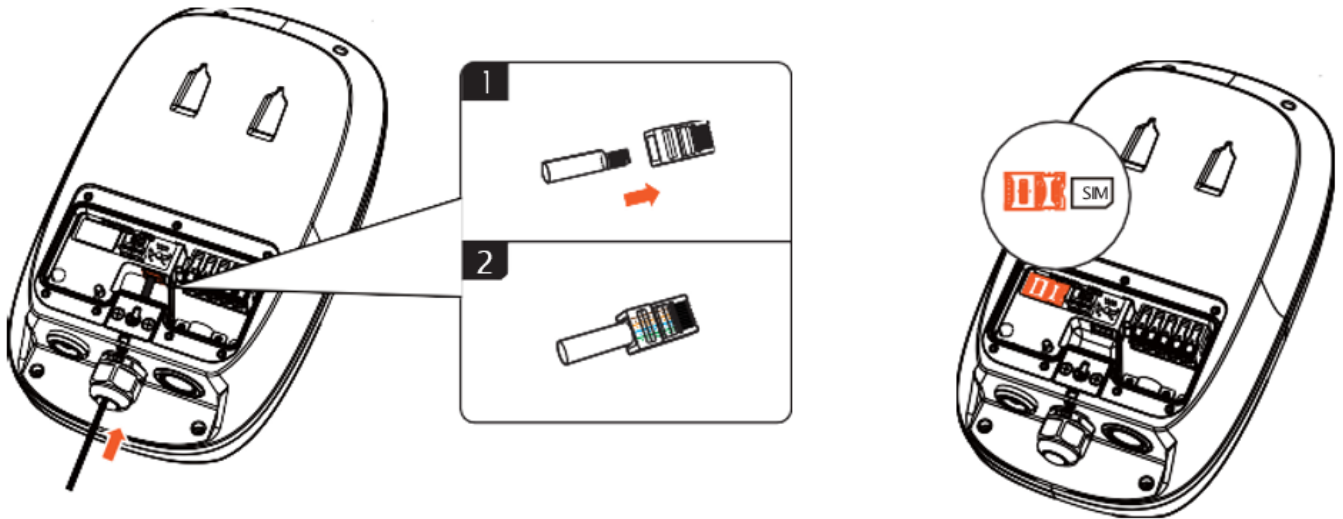

## 6.5. Install charger

- 1) Place the positioning diagram on the wall, aligning it properly.
- 2) Make marks on the wall corresponding to the holes indicated on the diagram.
- 3) Drill three holes, each 40mm deep, at the marked spots.
- 4) Drive three wall plugs into the drilled holes, ensuring they are flush with the wall surface.
- 5) Drive two wall mounting screws into the upper two wall plugs, leaving a 5mm gap between the screw heads and the wall surface to form hooks.

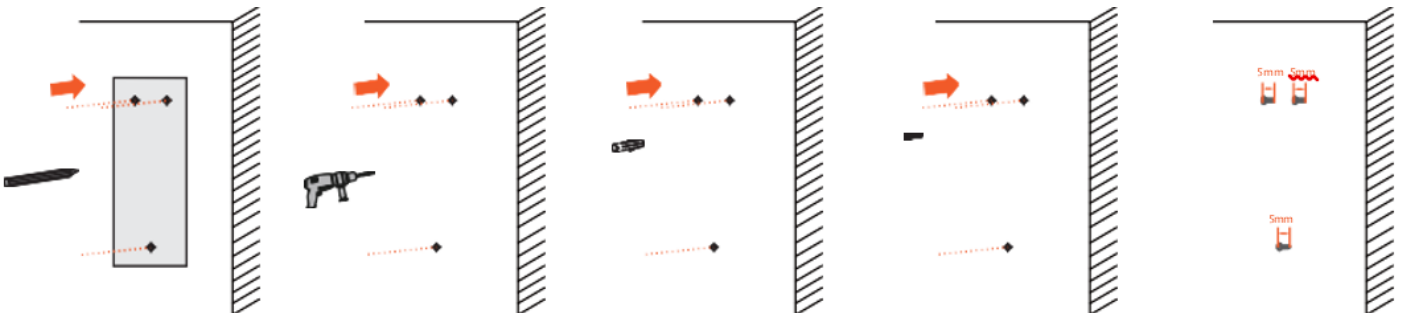

- 6) Secure the charger to the wall-mounting screws

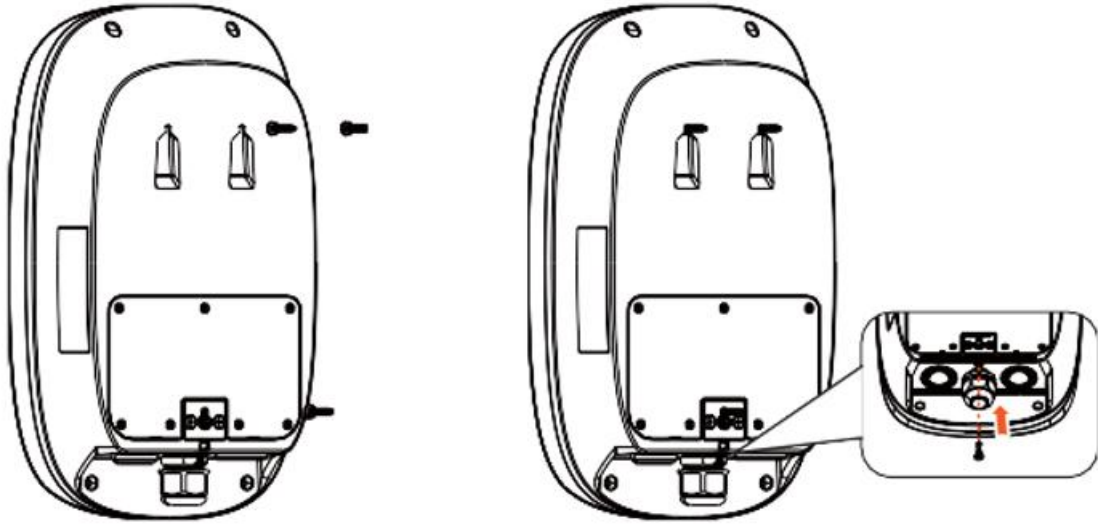

7) Install cable holder

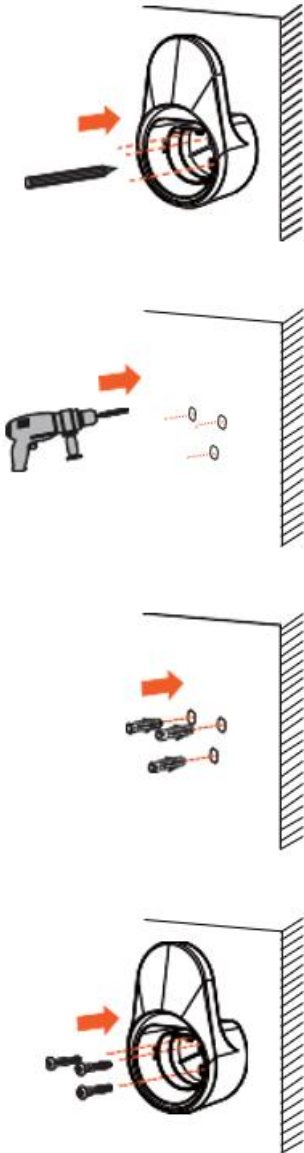

8) Installation completed

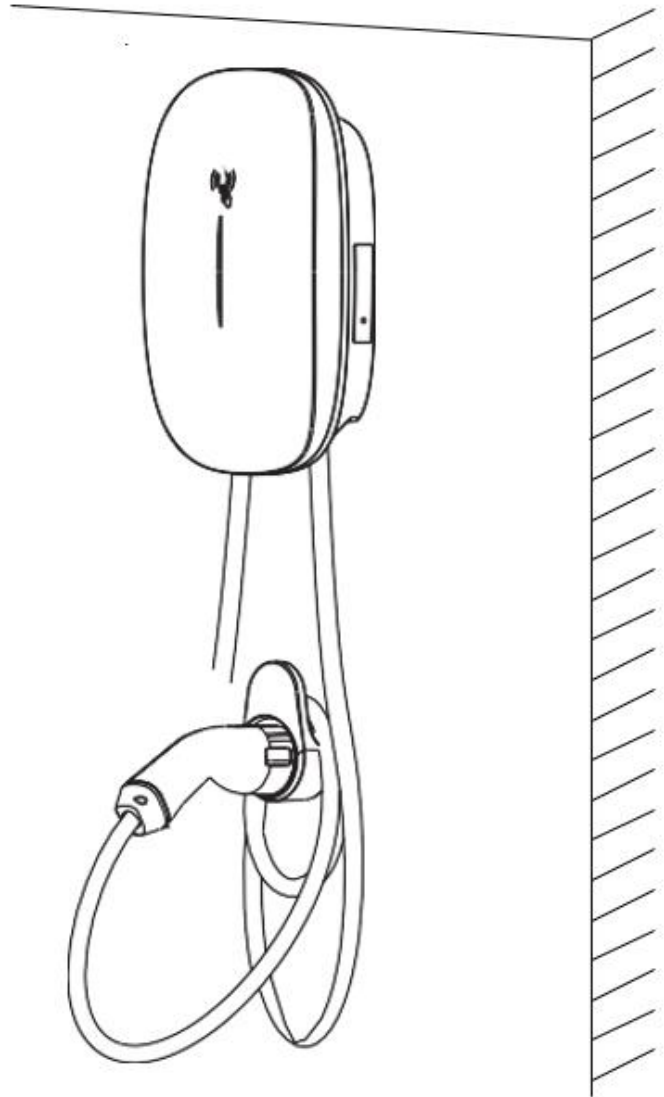

## 7. Configure the Charger

The configurations are different in residential scenario and commercial scenario

### 7.1. Configuration by AP mode

#### 7.1.1. Preparation

##### **Activate the Hotspot:**

Activate the hotspot of the charger by restarting the power.

The hotspot of the charger remains available for 15mins since charger reboot.



##### **Connect to Charger Hotspot:**

Turn on the smartphone Wi-Fi, and connect the hotspot of the charger. If unable to connect, try using Airplane mode.

The name of the hotspot Wi-Fi starts with the charger SN number, i.e. "SN...".

The password is on the last page of this guide.



#### 7.1.2. Login

Open the browser on your smartphone and enter 192.168.4.1 in the address bar.

Log in using the four-digit PIN code located on the last page of the user manual. After login, the function menu will be displayed.

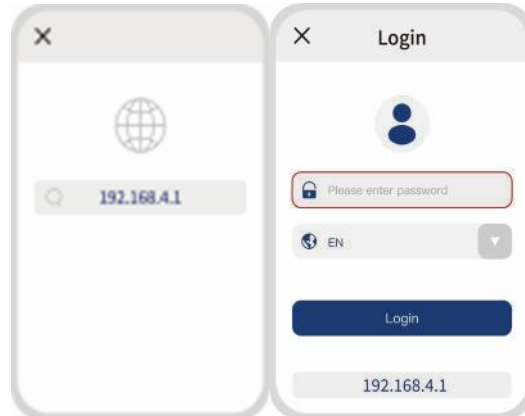

Please press the reset button and hold on for 5s to reset:

- If you change the password to log in AP mode, but forget it later.
- If you forget the Bluetooth password

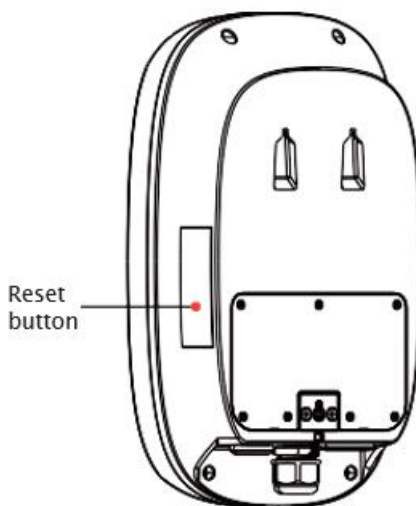

After logging in click [Network Settings](#) to configure the network.

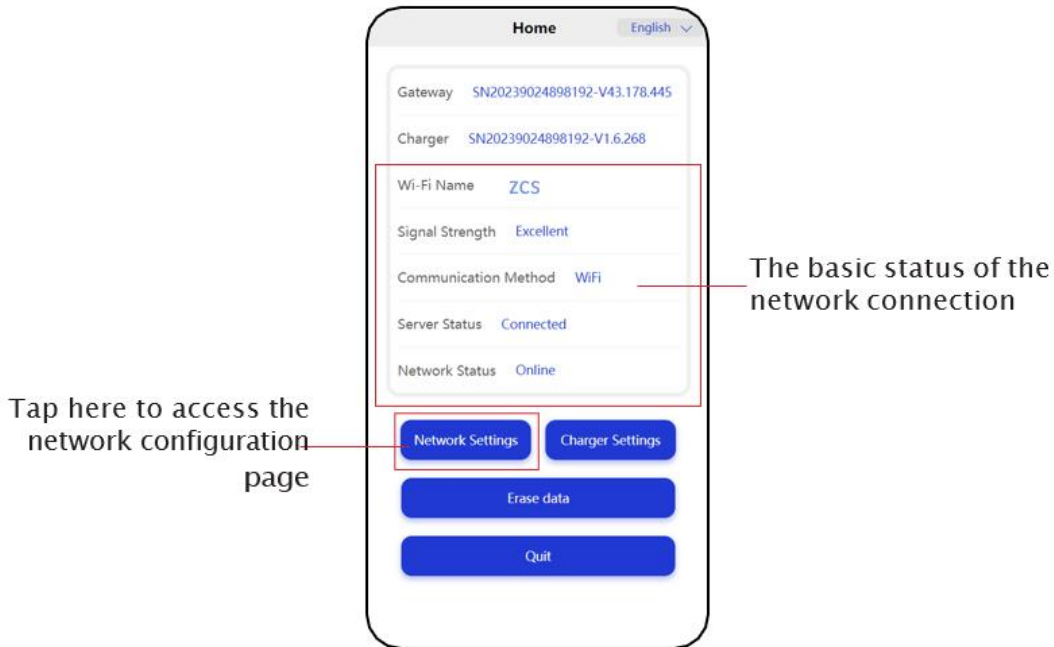

- After completing the network settings, tap 'Confirm'>'Save'. The charger will restart automatically, and your phone will be disconnected from the charger's Wi-Fi hotspot.

## 7.2. Commercial Scenario

- Connect to Evchargeo platform in a commercial scenario
- Connect to a 3<sup>rd</sup> party's platform, and use a 3<sup>rd</sup> party's APP to charge EV.

### 7.2.1. Evchargeo platform

To use the monitoring portal, please refer to the dedicated documentation on the website <http://www.zcsazzurro.com/>.

In the section relating to charging stations, consult the document "Evchargeo Portal User Manual"

To create the account on the new portal: <https://cloud.evchargeo.com/> please send us an email with the following data so that we can activate it and correctly configure the new account:

- company name
- account name
- email to register with

Send us this data by opening a ticket from our website <http://www.zcsazzurro.com> in the Support/Request assistance and commercial info section.

Once your account is created, you will receive a notification email from [notification@evchargeo.com](mailto:notification@evchargeo.com) with your account password.

## 7.2.2. Third-Party Platform

In case you need to configure the wallbox with a third-party portal, follow the procedure:

### Turn on the charger's hotspot:

Turn on the charger's hotspot by restarting the power.

The charger hotspot remains available for 15 minutes after the charger is restarted.



### Connect to the charger hotspot:

Turn on your smartphone's Wi-Fi and connect the charger hotspot. If you can't connect, try using airplane mode.

The name of the Wi-Fi hotspot starts with the SN number of the charger, which is "SN..." .

The password is admin123.



### Access

Open the browser on your smartphone and enter 192.168.4.1 in the address bar.

Log in using the four-digit PIN code found on the last page of the manual or inside the box. After logging in, the function menu will be displayed.

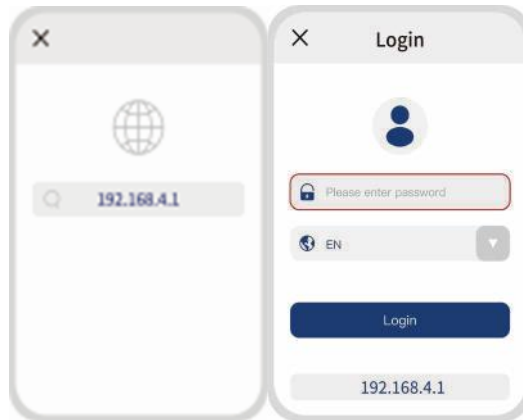

Once logged in, click on *Network Setting*. Finally, change the *endpoint* to the one for the third-party portal and press Confirm.

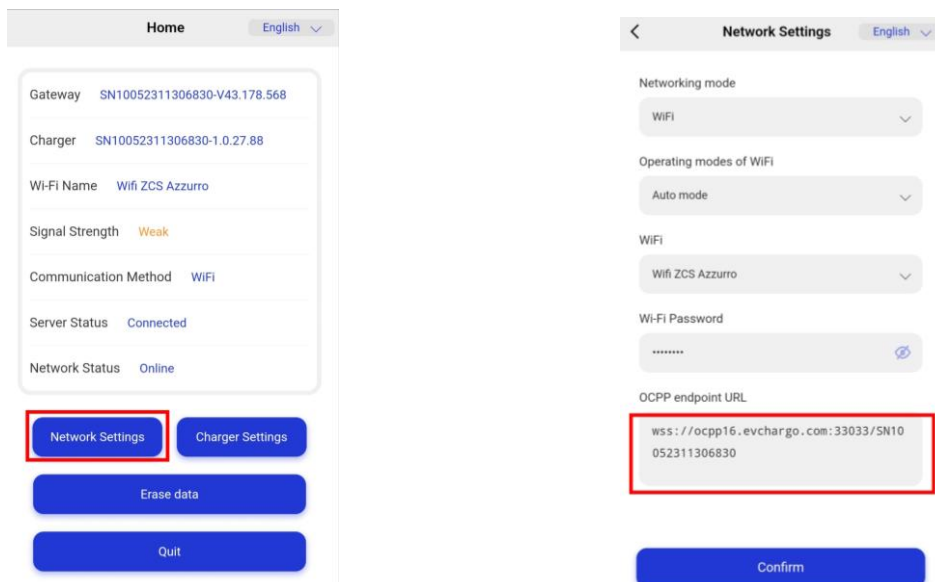

### 7.2.3. Use 4G for Communication

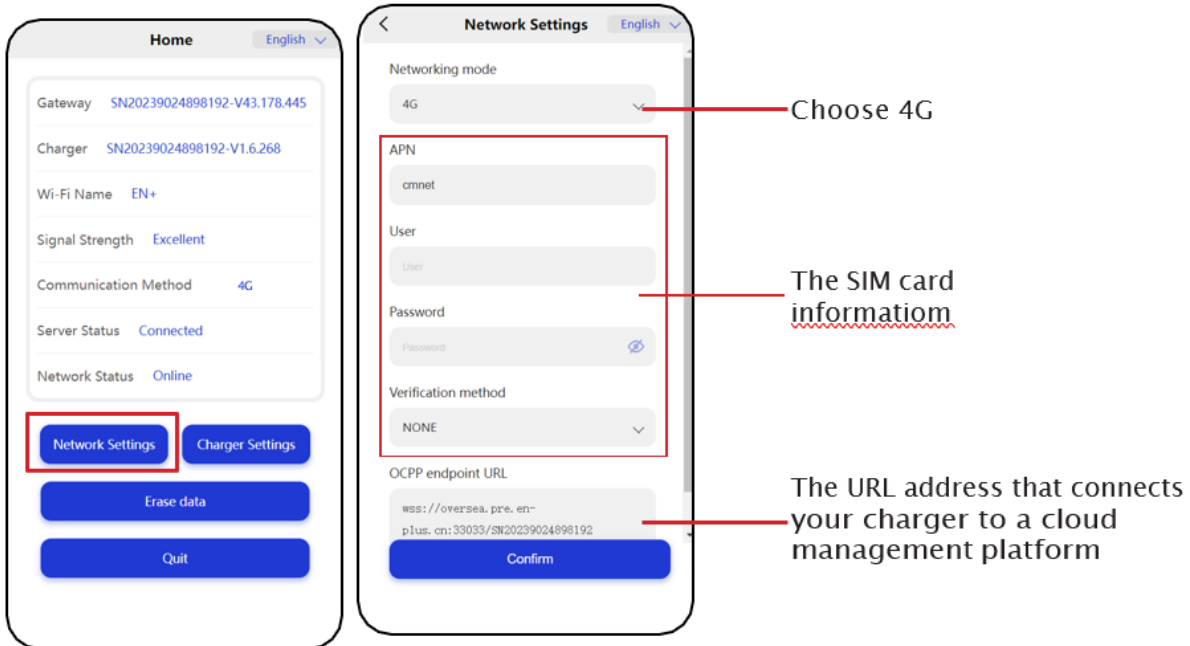
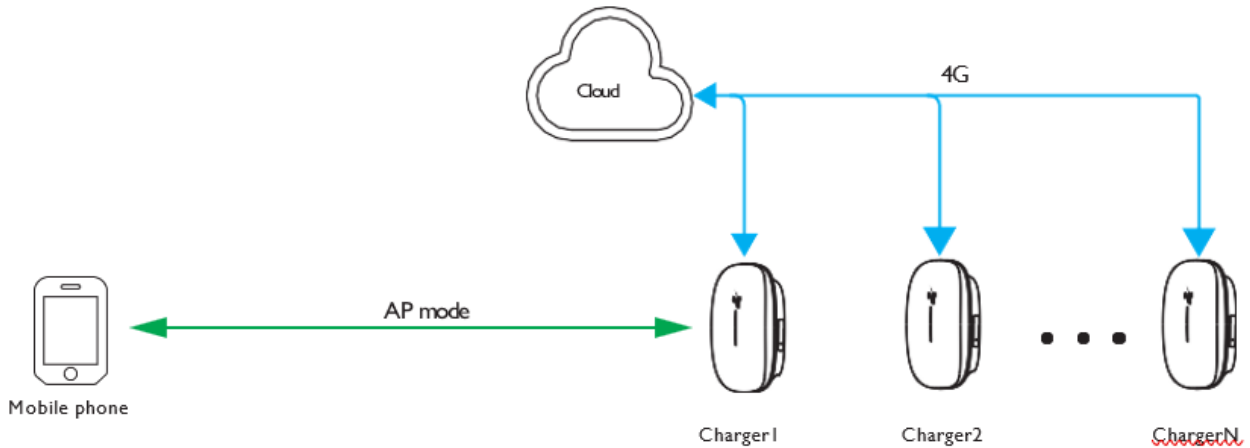

### 7.2.4. Use Wifi for Communication

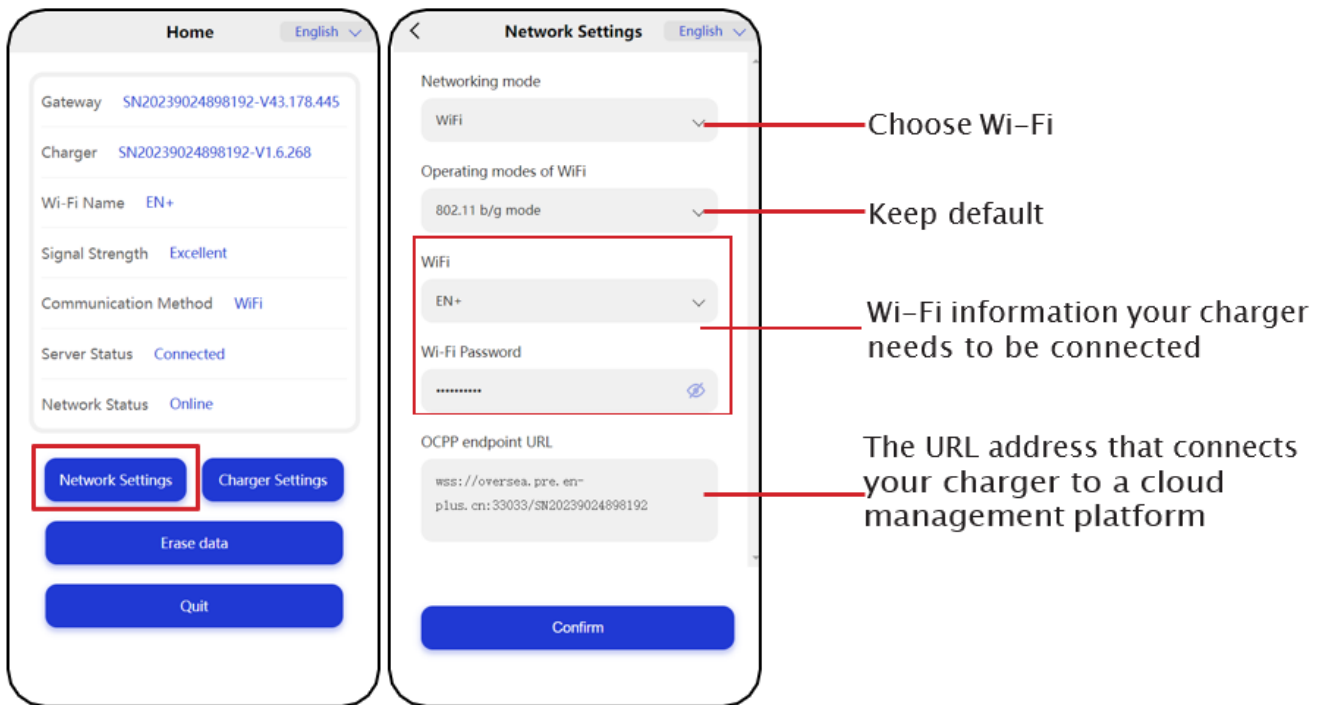
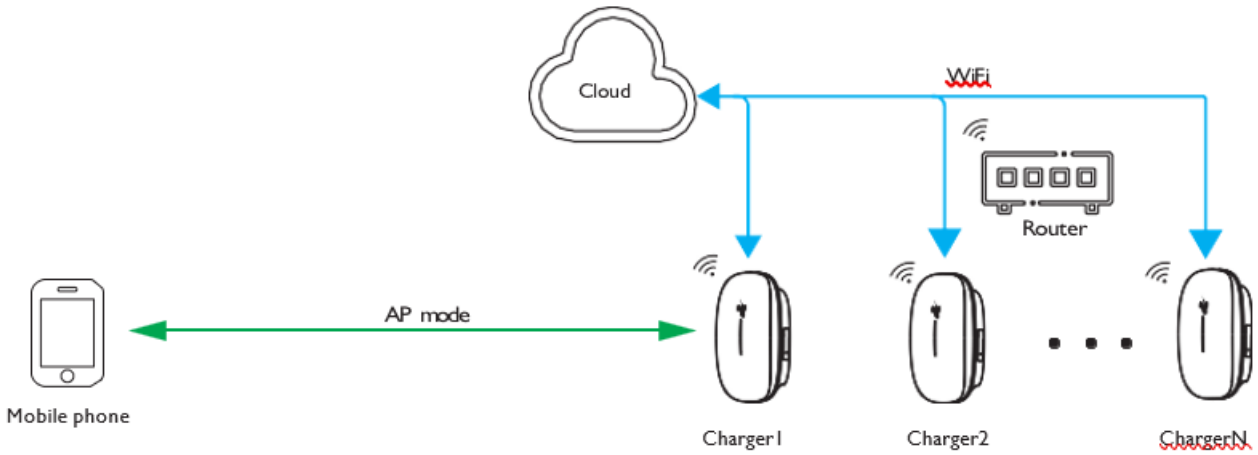

### 7.2.5. Use Ethernet for Communication

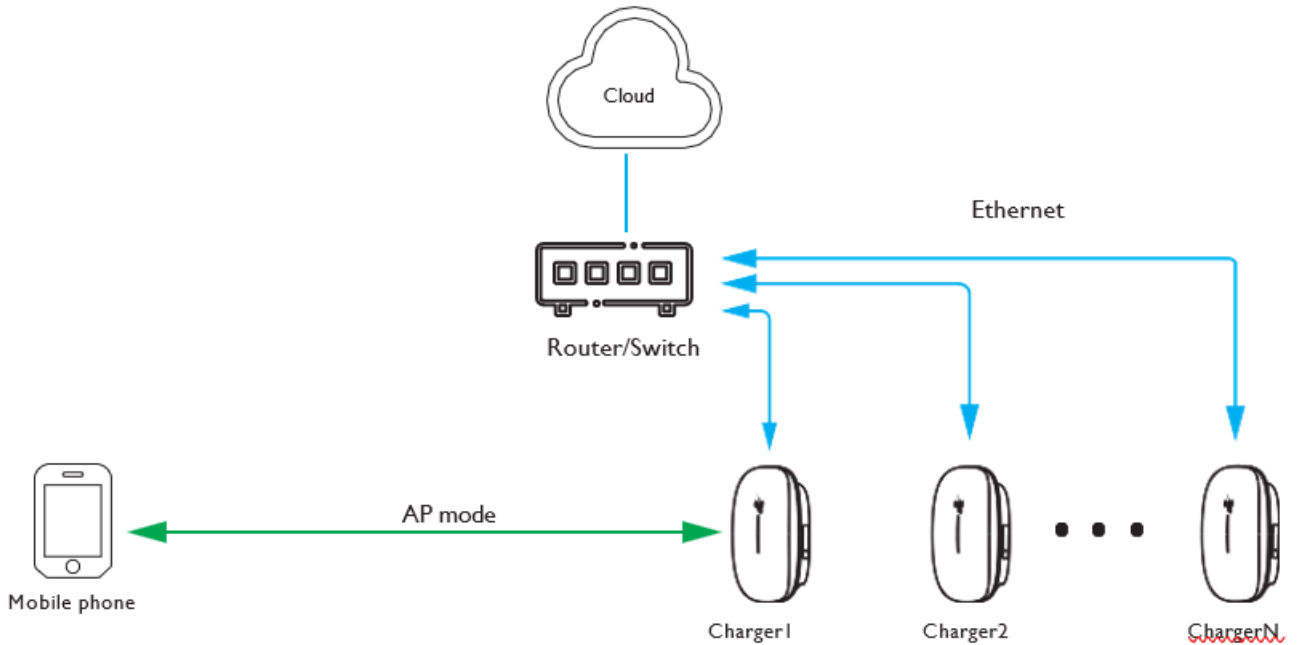

### 7.3. Residential Scenario

Evcharge APP is recommended for the charger used in a residential scenario.

#### 7.3.1. Evcharge APP configuration

Evcharge is an APP that allows electric vehicle drivers to locate public charging stations and intelligently manage their home charging point. It has a simple, easy-to-use design and is dedicated to offering users the best charging and service experience possible.



Evcharge Download  
(IOS&Android)

|   |   |
|---|---|
|  | <ul style="list-style-type: none"> <li>• <b>If you are an installer, you can download and install Evcharge App, and after completing all necessary configurations, you can transfer the ownership to the user.</b></li> <li>• <b>The user then simply installs the App and log in to easily control the charging process with the App.</b></li> </ul> |
| <b>Attention</b>  |   |

#### 7.3.2. Sign Up and Log In

✓ **Account creation:**

Open the app and tap "Sign Up" to create a new account. Enter your Email address, set a password and confirm your details.

✓ **Login:**

To login, enter your email and password.

✓ **Select Scenario:**

Select the second one: home use

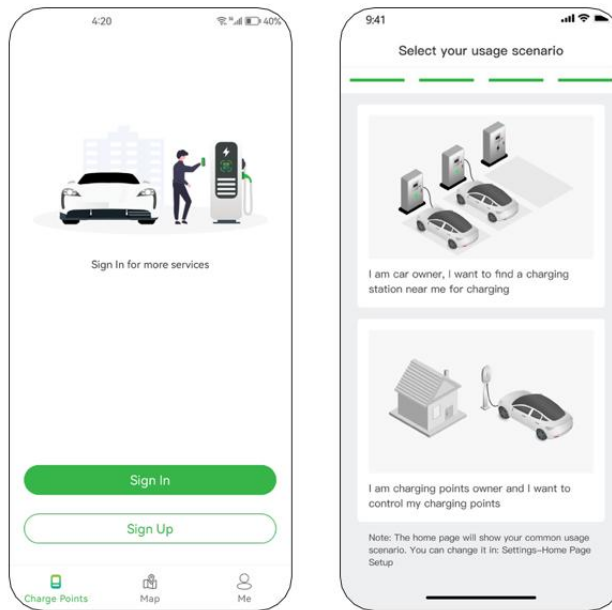

### 7.3.3. Bind Charger to App

- ✓ Turn on Bluetooth, Wi-Fi and GPS in your mobile phone.
- ✓ Add the charger through the provided methods.
- ✓ Select the brand of your charger.

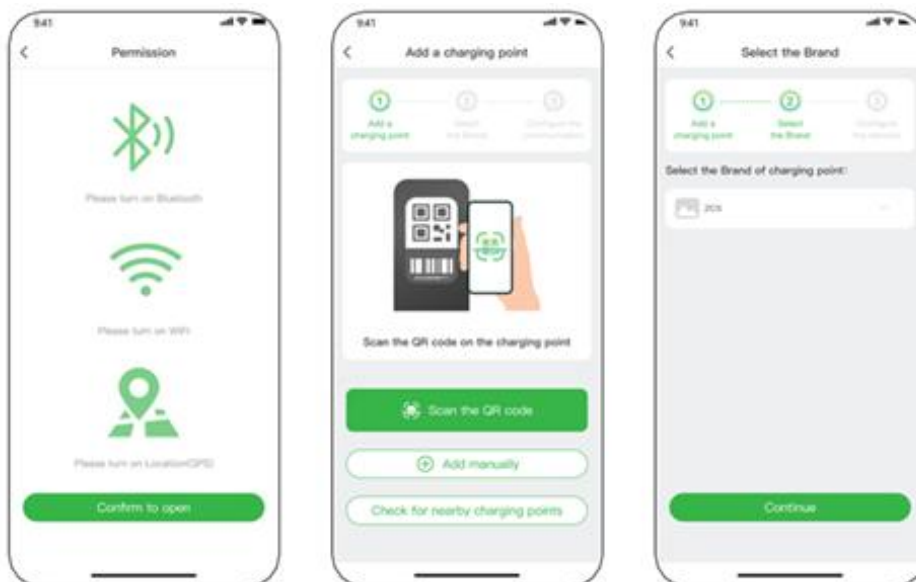

### 7.3.4. Select Communication Mode

- ✓ The communication modes determine the charging modes you use to charge EV.
- ✓ If Bluetooth mode and plug to charge mode are selected, it will jump to the charging control page directly.
- ✓ If online mode is selected, you need to configure network (Wi-Fi, Ethernet or 4G) for the charger.

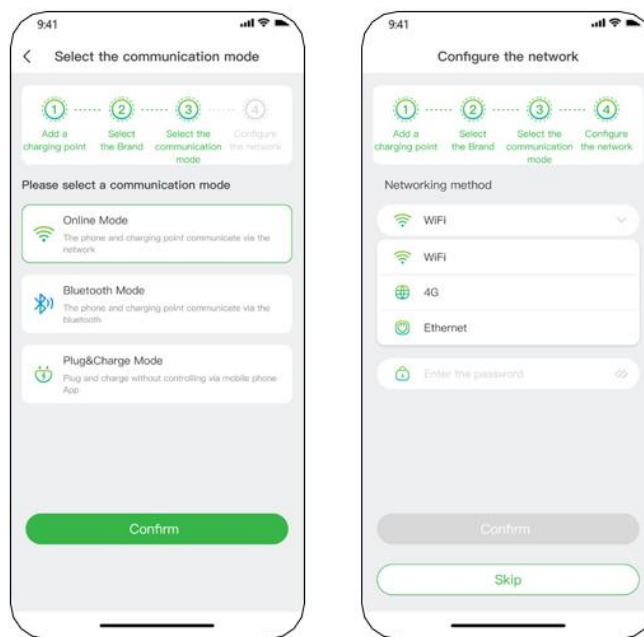

### 7.3.5. Set Maximum Charging Current

The main fuse or circuit breaker in the property's consumer unit should be labelled to state the maximum load. It is imperative that the maximum charging current is configured in such a way that the property's power supply remains uninterrupted, even at peak usage, while ensuring that all other household appliances continue to function without disruption.

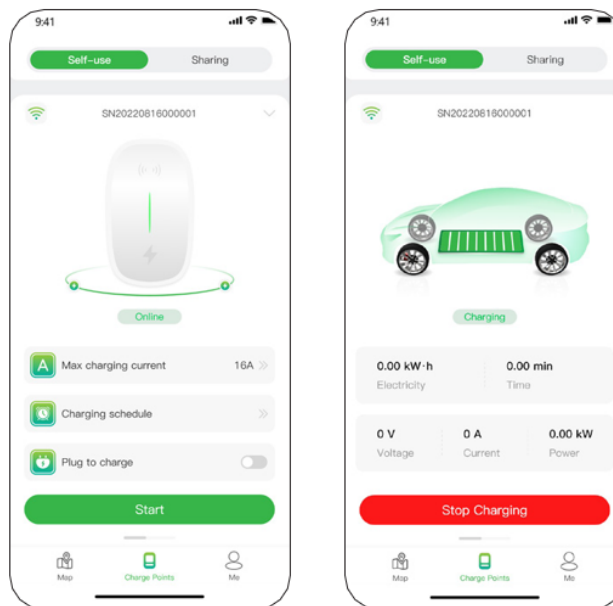

### 7.3.6. Transfer Ownership to End User

If you are an installer, after completing the above step and no other functions such as load balancing, PV charging are required, you can use the "Transfer Ownership" feature within the APP to transfer account control to the user. This way, the user can easily control charging without any additional configuration through the APP.

1. wipe down on the charging page.
2. Tap "Transfer ownership".
3. Enter the email address of the receiver.

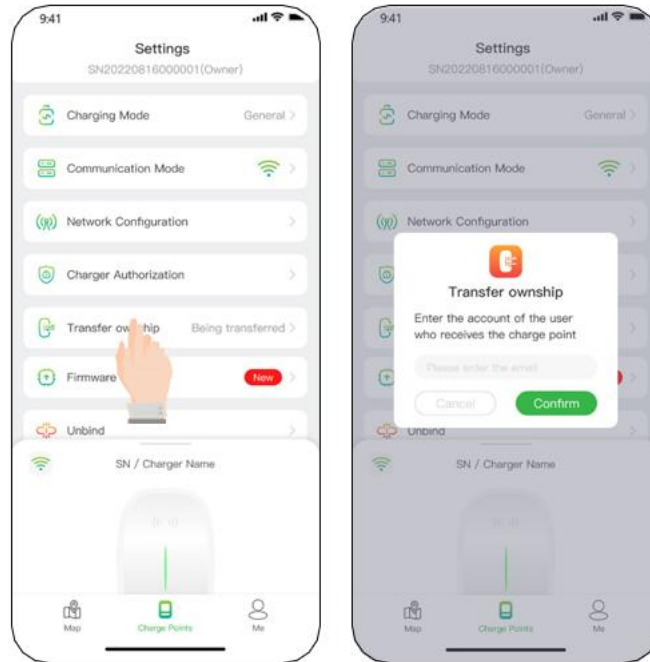

### 7.3.7. Set the RFID Card

The RFID cards provided with the charger can only be used when the charger is offline. However, if the end user wish to use the card when the charger is online, you will need to link the card with your charger in APP. The steps are as follows:

- Tap 'Me' > 'Card Management' to enter the card management page.
- Tap 'RFID card' > 'Add a card', then enter the number on the card.
- Place the card on the card sensor area to start charging.

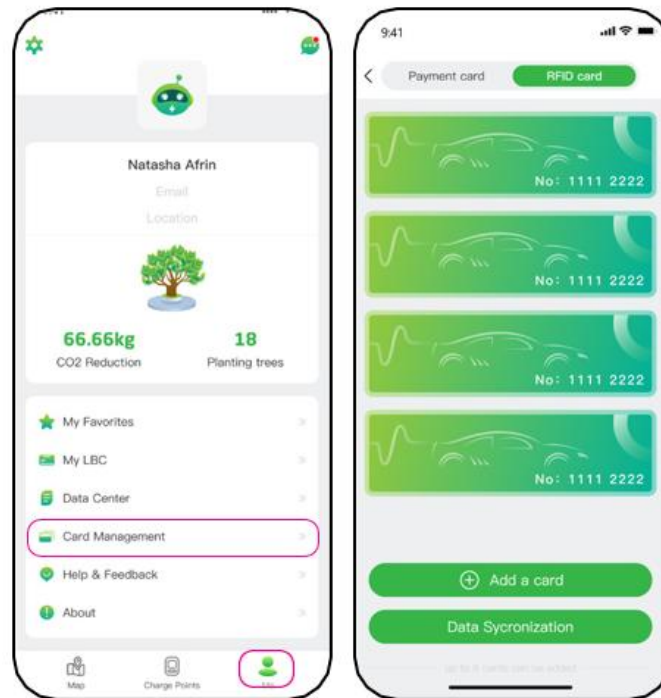

### 7.3.8. Charging Operation

#### Plug to charge

1. Turn on the "plug to charge" toggle.
2. Plug the charging connector in, and the indicator
3. flashes green quickly for five times.
4. The indicator gradually brightens, then gradually dims in green while charging in progress.
5. The charging session will be stopped by EV side upon it is fully charged.

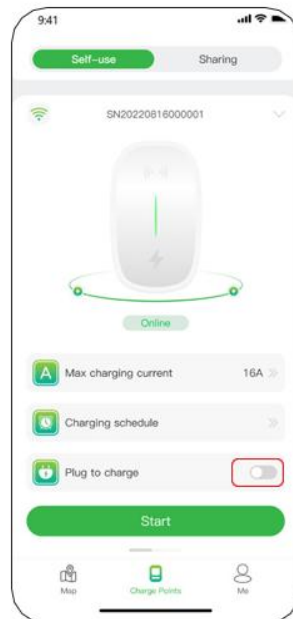

## Control charging via APP

Controlling charging process via App is convenient, with two options available: Ethernet/Wi-Fi/4G, or via Bluetooth.



### Attention

- **For the Bluetooth, it's important to maintain your phone within the Bluetooth communication range of charger to ensure a reliable and stable connection.**

- ✓ Plug the charging connector in, and The indicator flashes green quickly for five times.
- ✓ Tap "Start" button in the screen, and the indicator gradually brightens, then gradually dims in green while charging in progress.
- ✓ The charging will be stopped automatically as EV is fully charged, or you can tap "Stop" button to stop charging.

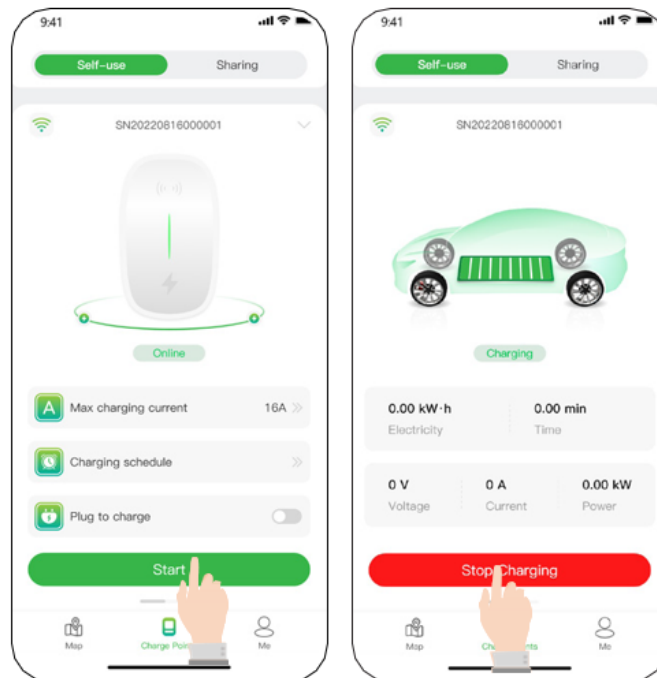

## Scheduled charging

Scheduled charging for EVs lets you set specific times to charge your electric vehicle, helping you save on electricity costs and reduce strain on the grid.

- ✓ Plug the charging connector in, and the indicator flashes green quickly for five times.
- ✓ Tap "Charging schedule" to create a schedule.
- ✓ The charging will start automatically upon reaching the specified time.
- ✓ The charging will be stopped automatically as EV is fully charged, or you can tap "Stop" button to stop charging.

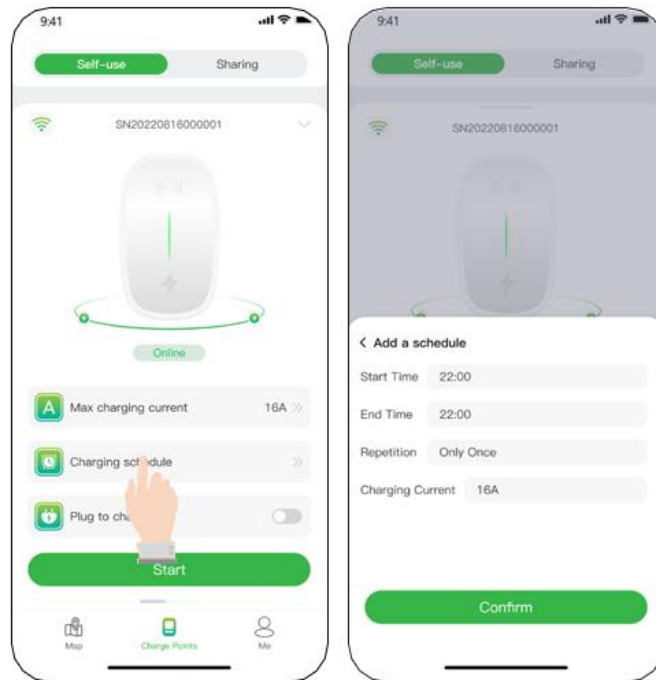

### Charging by swiping card

- ✓ Plug the charging connector in, and the indicator flashes green quickly for five times.
- ✓ Swipe card, and the indicator flashes yellow quickly for up to five times.
- ✓ During charging, the indicator gradually brightens, then gradually dims in green.
- ✓ Swipe card and unplug to the connector.

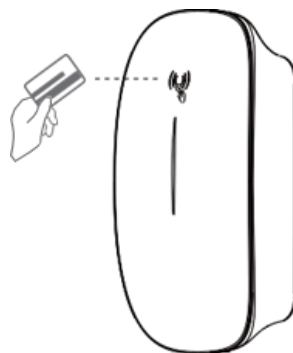

## 8. Dynamic Load Balancing

In the single charger scenario, the charger supports dynamic load balancing. By integrating a meter or a meter & three CTs, the charger can dynamically adjust its charging power to ensure that the electrical system remains within the capacity limits and not overload.

|   |  |
|---|--|
| <br><b>Attention</b> | <ul style="list-style-type: none"> <li>• <b>Current Transformers (CT) and meter are sold separately. If you need these items, please contact technical support team. This is essential because a thorough commissioning is required to ensure they work seamlessly with the charger to achieve the desired functionality.</b></li> </ul> |
|---|--|

Here are the available solutions for your reference:

| Product          | Scenario  | Associated equipment |
|------------------|---|----------------------|
| ZV3-22K-CARO-CAB | 1. Total power Load in consumer unit $\leq 80A$<br>2. The distance between meter and Charger $\leq 100m$  | Meter *1             |
|                  | 1. Total power Load in consumer unit $\leq 150A$<br>2. The distance between meter and Charger $\leq 100m$ | Meter*1 CT *3        |

### 8.1. Wiring for Dynamic Load Balancing

Based on the solutions shown above, for the hardware wiring of the dynamic load balancing.

#### 8.1.1. Introduction Load Balancing

This guide provides a step-by-step implementation process for the Dynamic Load Balancing solution, enabling efficient

energy distribution for Electric Vehicle (EV) chargers.



We will introduce the implementation of load balancing from five key aspects:

- ✓ The charger supporting load balancing in our company
- ✓ The required accessories and specifications
- ✓ The scenarios where the load balancing is applicable.
- ✓ The hardware wiring

- ✓ The software configuration

### 8.1.2. Applicable Scenarios and Required Accessories

Our solution is designed to provide you with a customized load balancing solution based on the total current capacity of your home and the power of your charger.

| Solution No.      | Required accessories                    | Phase of charger | Total Current        | Photo   |
|-------------------|---|------------------|----------------------|---|
| ZVM-CARO-METER-01 | One meter                               | Three phases     | Total current < 80A  |    |
| ZVM-CARO-METER-02 | One meter<br>Three current transformers | Three phases     | Total current < 150A |  |

### 8.1.3. Specifications

| Model No.                            | ZVM-CARO-METER-01                   | ZVM-CARO-MATAER-02  |
|--------------------------------------|-------------------------------------|---------------------|
| Voltage range                        | 3x230V/400V                         |                     |
| Consumption                          | <10VA(Single phase)                 | <10VA(Single phase) |
| Impedance                            | > 2M $\Omega$                       | > 2M $\Omega$       |
| Accuracy class                       | Error $\pm$ 0.2%                    | Error $\pm$ 0.2%    |
| Input current                        | 3x10(80)                            | -                   |
| Frequency                            | 45~65Hz, error $\pm$ 0.2%           |                     |
| Energy                               | Active energy (accuracy class:0.5)  |                     |
| CT clamps                            | No                                  | Yes                 |
| Interface and communication protocol | RS485: Modbus RTU                   |                     |
| Range of communication address       | Modbus RTU:1~245                    |                     |
| Baud rate                            | 1200bps~38400 bps                   |                     |
| Working temperature                  | -25 $^{\circ}$ C ~ +55 $^{\circ}$ C |                     |
| Working humidity                     | 5%~95%                              |                     |
| Working altitude                     | <2000m                              |                     |
| Warranty                             | 2 years                             |                     |

## 8.1.4. Hardware Wiring

### Load balancing via meter only

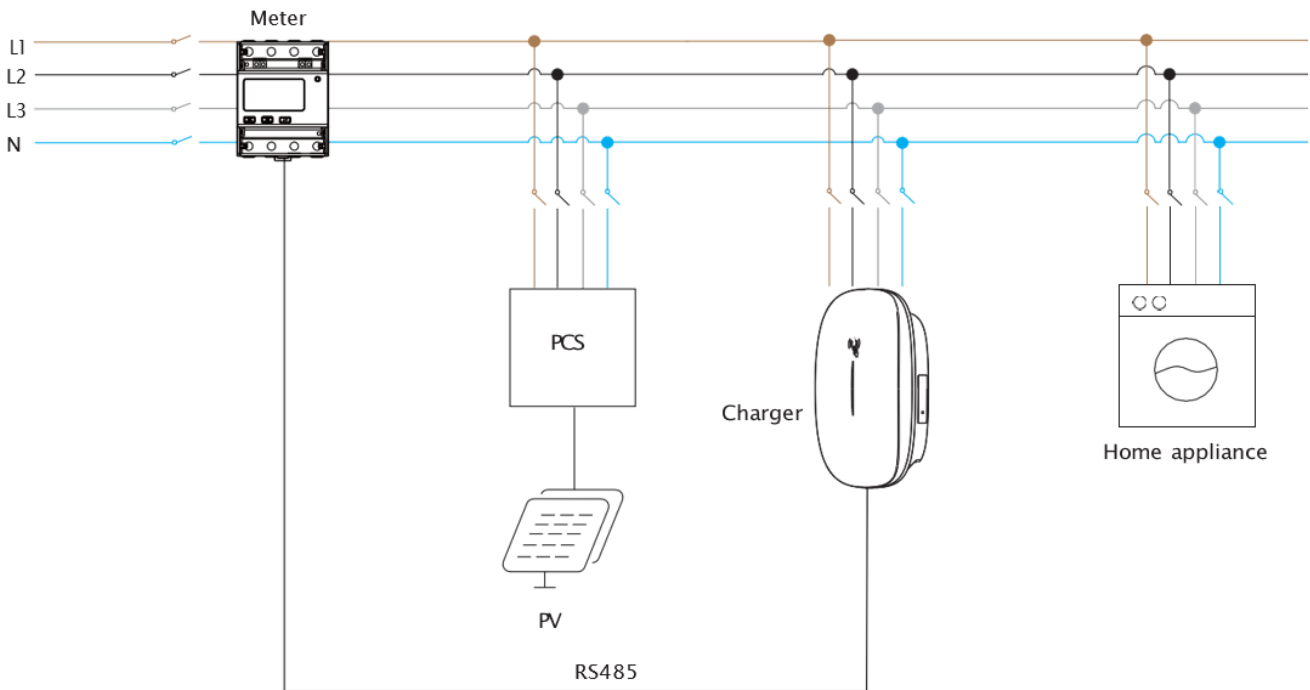

| Line  | Line color     | Port of meter | Port of the EV charger |
|-------|----------------|---------------|------------------------|
| L1    | Brown          | L1            | L1                     |
| L2    | Black          | L2            | L2                     |
| L3    | Gray           | L3            | L3                     |
| N     | Blue           | N             | N                      |
| PE    | Green + Yellow | /             | PE                     |
| RS485 | Red            | 21            | A                      |
|       | Black          | 22            | B                      |

### Caro\_Three phases\_Meter + CT

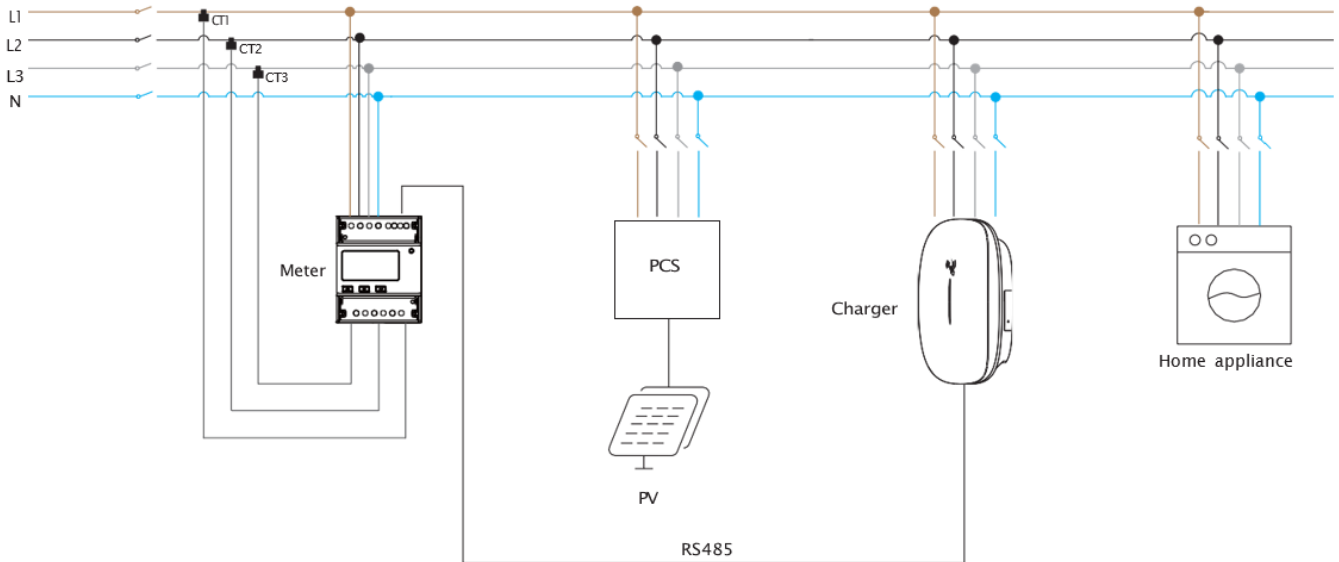

| Line  | Line color     | CT | Port of meter | Port of the EV charger |
|-------|----------------|----|---------------|------------------------|
| L1    | Brown          | /  | UA            | L1                     |
| L2    | Black          | /  | UB            | L2                     |
| L3    | Gray           | /  | UC            | L3                     |
| N     | Blue           | /  | UN            | N                      |
| PE    | Green + Yellow | /  | /             | PE                     |
| RS485 | Red            | /  | 21            | A                      |
|       | Black          | /  | 22            | B                      |
| CT1   | Red            | /  | 1A            | /                      |
|       | White          | /  | 1A*           | /                      |
| CT2   | Red            | /  | 1B            | /                      |
|       | White          | /  | 1B*           | /                      |
| CT3   | Red            | /  | 1C            | /                      |
|       | White          | /  | 1C*           | /                      |

## 8.2. Software configuration

### 8.2.1. Configured via APP

After completing the hardware wiring, you also need to configure it within the APP.

Accessing Settings:

Scroll down in the charging page of Evcharge app, find "Charging mode", as shown:

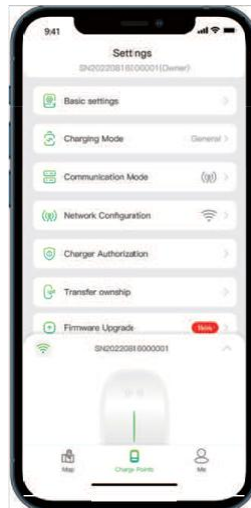

Choose the monitoring method based on the accessories you choose to achieving load balancing.

If you opt for the "Smart Meter + CT" configuration, ensure that the CT ratio is set to 150:5 for proper functionality.

Regarding "Max Load Current," this refers to the maximum current threshold that your home's electrical system can handle without tripping. It's the limit beyond which the circuit breaker will activate to prevent overloads.

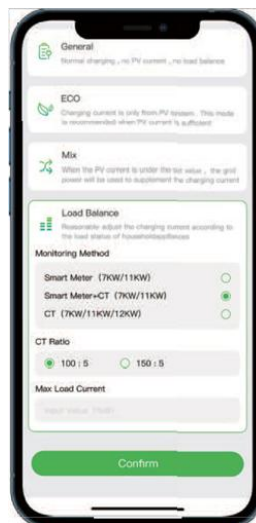

For the use of the monitoring portal, please refer to the dedicated documentation on the website <http://www.zcsazzurro.com/>.

In the section on charging stations see the document "User Manual Evcharge Portal"

## 8.2.2. Configured via AP mode

AP Mode, also known as Access Point Mode, is a versatile wireless networking feature that enables devices like EV charger to function as Wi-Fi access points, establishing a dedicated hotspot. Users can effortlessly connect their smartphones or other mobile devices to this hotspot and manage the device through a web interface by navigating to a designated IP address, such as 192.168.4.1. This setup facilitates remote monitoring and configuration of the device, eliminating the need for physical interaction and ensuring a user-friendly and secure wireless management experience.

- Enter the password which can be found on the last page of the charger's installation guide to connect the charger to your phone.
- To access the Login page of AP mode, enter the IP address 192.168.4.1 in a browser, followed by the 4-digit password: a PIN number, which can be found on the last page of the charger's installation guide.

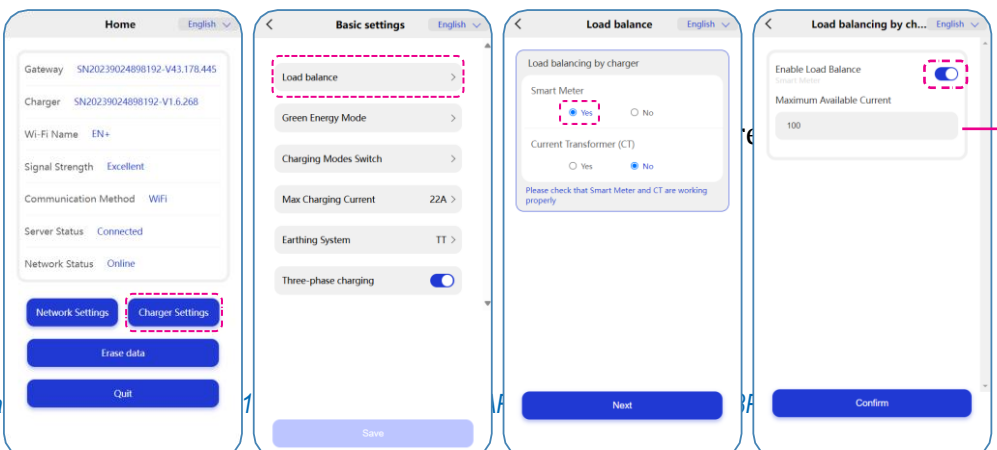
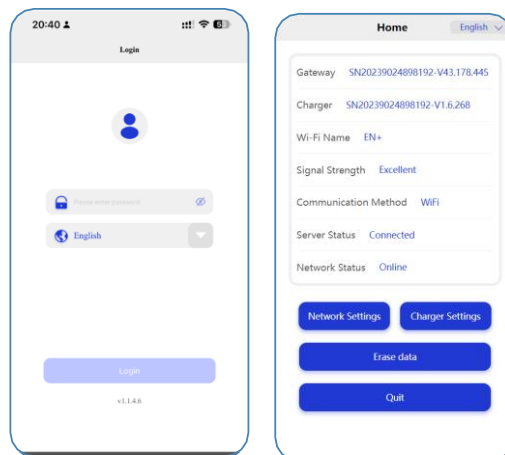

Ma

**NOTE** You must tap 'Confirm' once you have finished configuring the charger. The charger will power cycle and take a few minutes to comeback online.

## 9. Indicator

| Indicator colour | Indicator status   | Charger status   |
|------------------|--|--|
| Green            | Cycle: flash slowly (on for 1s then off for 3s)  | Charger standby  |
|                  | Cycle: flash green twice (on for 200ms and off for 1000ms), then off for 3000ms        | Charger started successfully, and wait for EV's response |
|                  | Cycle: flash green five times (on for 200ms and off for 1000ms), then off for 3000ms   | Charging connector plugged                               |
|                  | Gradually brightens, then gradually dims in green at interval of 1s                    | Charging in progress                                     |
|                  | Steady green   | Charging ended   |
| Yellow           | Steady yellow  | Warnings   |
|                  | Cycle: flash yellow five times (on for 200ms and off for 1000ms), then off for 3000ms. | Insufficient power allocated, charging suspended         |
|                  | Cycle: flash yellow for up to five times (on for 100ms and off for 100ms).             | Successful card swiping                                  |
|                  | Cycle: flash green and flash yellow alternately for 1s then off for 3s                 | No network/Not connected to the server                   |
| Red+ Yellow      | Flash red/Steady red Flash red and yellow  | Faulty   |
| White            | Fade in and out at intervals of 1s   | Self-test upon power on                                  |
|                  | Cycle: flash white five times (on for 200ms and off for 1000ms), then off for 5000ms   | Firmware upgrading                                       |

## 10. Troubleshooting

This section contains information and procedures on how to troubleshoot any faults and errors that may occur during operation of the charging station.

If you have any problems please follow these steps:

- 1) Check the warning messages and error codes on Evcharge APP.
- 2) If the charging station does report any errors, perform the following checks:
  - Is the device located in a clean, dry and properly ventilated place?
  - Are the cables correctly sized and as short as possible?
  - Are the connections in good condition?
  - Are the configuration settings correct for the type of installation?

Information on the event list:

| Indicator color                     | Charger status   | Indicator status   |
|-------------------------------------|--|--|
| Red                                 | Relay adhesion   | Steady red   |
|                                     | Leakage current  | Cycle: flash red once then off for 3s  |
|                                     | CP fault   | Cycle: flash red twice then off for 3s                                       |
|                                     | Over current   | Cycle: flash red 3 times then off for 3s                                     |
|                                     | Input wires are connected reversely                              | Cycle: flash red 4 times then off for 3s                                     |
|                                     | Leakage current loop is abnormal                                 | Cycle: flash red 5 times then off for 3s                                     |
|                                     | Input terminals over temperature                                 | Cycle: flash red 6 times then off for 3s                                     |
|                                     | Relay over temperature   | Cycle: flash red 7 times then off for 3s                                     |
| Red + Yellow                        | Over/under voltage   | Cycle: stay yellow for 2s then flash red once then off for 3s                |
|                                     | Over/under frequency   | Cycle: stay yellow for 2s then flash red twice then off for 3s               |
|                                     | Meter communication is abnormal                                  | Cycle: stay yellow for 2s then flash red 3 times then off for 3s             |
|                                     | Smart Meter communication is abnormal                            | Cycle: stay yellow for 2s then flash red 4 times then off for 3s             |
|                                     | Charging connector lock abnormal                                 | Cycle: stay yellow for 2s then flash red 6 times then off for 3s             |
| Charging connector current abnormal | Cycle: stay yellow for 2s then flash red 7 times then off for 3s |  |
| White                               | BOOT security verification failed or the security chip failure   | Cycle: flash twice (on for 200ms and off for 1000ms for) then off for 5000ms |

## 11. Maintenance

Chargers do not need special maintenance. You are advised to check and clean the enclosure of the charger and accessories such as the charging connector every six months.

Check whether the charger and cables are damaged.

Use a dry cloth to clean the surface of the charger. Do not spray water directly on the charger.

|   |  |
|---|--|
|  | <ul style="list-style-type: none"> <li>• <b>Do not use corrosive cleaners, glass cleaners, or organic solvents.</b></li> </ul> |
| <b>Attention</b>  |  |

| No. | Item   | Operating process   |
|-----|--|---|
| 1   | Keep the charger clean.                            | Use a cloth to clean the charger surface.<br>If there is any damage or dirt on the vehicle connector, charging cable, or vehicle connector holder, please contact customer service immediately.                       |
| 2   | Keep the charger intact.                           | Do not hit or press hard on the case. If the case is damaged, please contact customer service.  |
| 3   | Avoid letting moisture or water enter the charger. | If there is water or moisture inside the charger, you must immediately switch off the electricity supply to avoid immediate danger. Please notify your maintenance professional before continuing to use the charger. |
| 4   | Avoid charger rusted.                              | Keep the charger away from dangerous substances such as flammable gases and corrosive materials.  |

### 11.1. Storage and Transportation

Chargers should be transported in the original packages. Do not place other objects on the top of the charger.

Before transportation, store the product in a clean, dry, and well-ventilated place with a relative humidity of not more than 80% and free from corrosive gases.

The environmental specifications for storage and transportation shall not go beyond those

specified in the Technical Specifications.

## 11.2. Disassembly

Only authorized and qualified electricians are allowed to disassemble the product.

Power off the charger before disassembling it. Disassemble a charger in the reverse order of installation.

## 11.3. Disposal/Scrapping

The product should be disposed of at recycling points for electronic equipment. Dispose of the product in a correct and environmental friendly manner in compliance with local laws and regulations.

Electronic devices cannot be disposed of as household waste.



## 12. Warranty

Zucchetti Centro Sistemi SpA provides a warranty of 2 years from the date of installation of the charging station, subject to registration on the website

<https://www.zcsazzurro.com/it/estensione-garanzia>. During the warranty period, Zucchetti Centro Sistemi S.p.A. guarantees the normal operation of the charging station.

If the device is defective or faulty during the warranty period, contact your installer or supplier. If the fault falls within the responsibility of the manufacturer, Zucchetti Centro Sistemi S.p.A. will provide service and maintenance free of charge.

### Warranty exclusions:

- Normal wear and tear.
- Damage or failure caused by unauthorized upgrades conducted by a customer.
- Damage or failure caused by external factors such as fire, flood, abnormal voltage, other natural disasters, and secondary disasters.
- Damage or failure caused by improper handling of the charger, such as impact from a fall and careless transportation after purchase.
- Damage or failure caused by a customer not following the user manual.

- Damage or failure caused by non-equipment factors like human error by a non-authorized individual carrying out maintenance.
- Unauthorized repairs will render the limited warranty void.
- Damage or failure caused by external factors such as power grid malfunctions.

**Limitation of liability:**

Ensure that the operator has the necessary skills and training to operate the equipment. Personnel responsible for the use and maintenance of the equipment must be qualified and able to perform the tasks described and must also have adequate knowledge of how to correctly interpret the contents of this manual. For safety reasons, this device may only be installed by a qualified and trained electrician who has the necessary skills and knowledge. Zucchetti Centro Sistemi S.p.A. declines all responsibility for damage to property and persons caused by incorrect use of the device.